



METEOROLOGICAL INSTRUMENTS

INSTRUCTIONS

Sentry™ Tunnel Visibility Sensor

MODEL 73000-90



R.M. YOUNG COMPANY 2801 AERO PARK DRIVE, TRAVERSE CITY, MICHIGAN 49686, USA

TEL: (231) 946-3980

FAX: (231) 946-4772

WEB: www.youngusa.com

Table of Contents

1.0	Introduction	1
1.1	How the Sentry™ Works	2
1.2	Specifications of the Sentry™	2
1.2.1	Description of Options & Accessories.....	4
1.2.1.1	Power Supply Options	4
1.2.1.2	Analog Options	5
1.2.1.3	Hood Heater Options	6
1.2.1.4	Accessories.....	7
1.3	Sensor Description	8
1.4	Signal Flow	14
2.0	Installation	15
2.1	Site Preparation.....	15
2.1.1	Siting Guidelines.....	15
2.1.2	Site Preparation.....	17
2.2	Mechanical Installation	18
2.3	Signal Wiring	19
2.3.1	Analog Voltage Output Connection	19
2.3.2	4-20 ma Current Loop Output Connection.....	21
2.3.3	3-Relay Output Connection for 74024X PCB	23
2.4	Electrical Power Installation.....	25
2.4.1	AC Power Connections	25
2.4.2	DC Power Connections (Optional).....	26
2.4.3	Earth Grounding Connections	28
3.0	Data Interpretation and Operation.....	29
3.1	Analog Voltage Output.....	29
3.2	4-20 ma Current Loop Output (Optional)	34
3.3	74024X 3-Relay Output (Optional).....	38
4.0	Calibration	41
4.1	Procedure for Calibrating the Analog Voltage Output Sentry™ Sensor.....	42
4.2	Procedure for Calibrating the Sentry™ with 4-20 ma Current Output.....	45
5.0	Maintenance.....	47
5.1	R.M. Young Co. Product Warranty:	47
5.2	Correcting Defects Under the Warranty.....	47
5.3	Preventative Maintenance	48
5.4	Corrective Maintenance.....	49
5.4.1	Initial Checks	49
5.4.2	Test Points.....	49
5.4.3	Troubleshooting Scenarios.....	52
5.4.4	Remove & Replace Instructions	53
5.5	Field Replaceable Units (FRU's).....	55
5.6	Training.....	55
Appendix	56

List of Figures

Figure 1.1-1 Forward Scatter Geometry	2
Figure 1.2.1-1 Sensor Label.....	4
Figure 1.3-1 Sentry™ Major Components.....	9
Figure 1.3-2 Main Enclosure Components (AC Power Version).....	11
Figure 1.3-3 Main Enclosure Components (DC Power Version).....	13
Figure 1.4-1 Sentry™ Signal Flow Diagram	14
Figure 2.1.1-1 Sensor Orientation	15
Figure 2.1.1-2 Typical Roadside Installation.....	16
Figure 2.1.1-3 Typical Tunnel Installation	16
Figure 2.1.2-1 Site Preparation – Concrete Footer.....	17
Figure 2.1.2-2 Site Preparation – Mounting Brackets	17
Figure 2.2-1 Mechanical Installation	18
Figure 2.3.1-1 Analog Output Voltage Connections	20
Figure 2.3.2-1 4-20 ma Current Loop Output Signal Connections	22
Figure 2.3.3-1 3-Relay Output Signal Connections	24
Figure 2.4.1-1 User AC Power Wiring	26
Figure 2.4.2-1 User DC Power Wiring	27
Figure 2.4.3-1 Earth Grounding.....	28
Figure 3.3-1 3-Relay Control Relay Adjustment Points	39
Figure 4.0-1 73062 Calibration Fixture.....	41
Figure 4.1-1 Calibration Test Points and Adjustment Points.....	42
Figure 4.1-2 Installation of ND4 Filter	43
Figure 4.1-3 Installing the Scatter Plate	43
Figure 5.4.1-1 LED Display	49
Figure 5.4.2-1 Signal Processor Diagnostic Test Points.....	49
Figure 5.4.2-2 AC Power Supply Test Points.....	50
Figure 5.4.2-3 DC Power Supply Test Points	51
Figure 5.4.4-1 Surge Module Wiring	53
Figure A-1 Sentry™ Schematic – AC Version	57
Figure A-2 Sentry™ Schematic – DC Version	58
Figure A-3 Sentry™ Schematic – Optional Hood Heaters.....	59

1.0 Introduction

Visibility is the term commonly used to express how far a person can see. But the question is actually quite complicated due to the complex psychological and physical nature of the measurement. As reported by the World Meteorological Organization (WMO), “any visual estimate of visibility is subjective.” Visibility, better known as meteorological optical range (MOR), is the greatest distance that a large dark object can be seen and recognized against a light sky background. Questions often arise as to the size and color of the object or target. The object must be large (subtend an angle of >0.5 degrees). Depending on the distance from the observer, a white church steeple that is 4 feet wide and 1000 feet away is an unacceptable target since it only subtends an angle of 0.2 degrees and is the wrong color. A light pole that is only 1 foot in diameter is an even worse choice as a target! Some of the other factors that affect a humans ability to measure visibility are the ambient light level, the persons corrected vision, and the training of that person to be a qualified weather observer. Even with all these factors equal between two trained observers, they will not agree in their assessment of the visibility.



Our ability to “see” a long distance is altered by what are known as obstructions to vision. These obstructions fall into two classes, hydrometeors that are wet and lithometeors that are dry. Examples of hydrometeors include rain, snow, fog, mist, drizzle, and spray. Examples of lithometeors include salt, pollen, smoke, and dust.

As light propagates through the atmosphere it is attenuated by absorption and scattering from these “obstructions to vision”. The Beer-Lambert-Boguers law gives the relationship between light attenuation and scattering and absorption. The fraction of light lost to scattering and absorption per unit distance in a participating medium is known as the extinction coefficient, σ . The standard unit of measure of extinction coefficient is km^{-1} .

Conversion from extinction coefficient to visibility involves different algorithms, one for daytime and one for night. Daytime visibility is related to the viewing of dark objects against a light sky as previously mentioned. For measurement of visibility in the daytime, Koschmieder's Law is used:

$$V = 3/\sigma$$

Where V is the visibility and σ is the extinction coefficient

Nighttime visibility is related to the distance at which a point source of light of known intensity can be seen. For measurement of visibility at night, Allard's Law is used:

$$V = e^{-\sigma V}/0.00336$$

Where V is the visibility and σ is the extinction coefficient.

Most users will use only the Koschmieder's ($V = 3/\sigma$) formula. The aviation community typically uses a photometer to measure the day/night condition and applies both formulas depending on the ambient background light.

Fortunately, sensors have been developed that can reliably measure visibility. They employ one of two methods to measure atmospheric visibility, either transmissivity or scattering. Sensors that measure the transmissivity of the atmosphere (transmissometers) are research tools that are often used as standards against which other sensors are compared. They are not practical for most automated systems due to their high cost to purchase, install, and maintain.

1.1 How the Sentry™ Works

The Sentry™ uses the principle of forward scattering as shown in Figure 1.1-1. The optical system is designed such that the infrared light projected from the transmitter (TX) intersects the field of view of the receiver (RX) with a forward angle of 42° . The area of intersection is known as the sample volume. The 42° forward angle ensures performance over a wide range of particle sizes in the sample volume including smoke, dust, haze, fog, rain and snow.

When the air is clear, very little light is scattered since there are few particles in the sample volume resulting in a small signal received by the sensor. As the number of particles in the sample volume increases, the amount of light detected by the receiver also increases. In other words, the received signal strength is inversely proportional to the visibility.

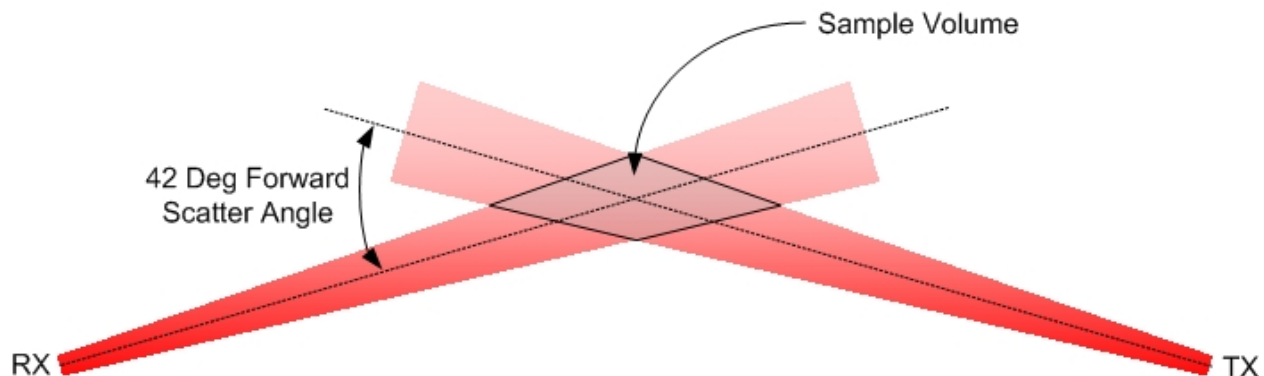

Figure 1.1-1 Forward Scatter Geometry

1.2 Specifications of the Sentry™

Performance in all weather conditions was a design requirement for the Sentry™. The integrated, one-piece housing design keeps all cabling internal to the sensor for the ultimate protection against the elements. The sensor housing is made from anodized aluminum and the enclosures are rugged, UV-resistant fiberglass and environmentally rated to IP66.

Based on the proven experience of the NWS and FAA, the sensor uses "look down" geometry to reduce window contamination and clogging from blowing snow. The windows use continuous duty anti-dew heaters and optional thermostatically controlled external hood heaters for protection in cold & snowy weather conditions. All power and signal lines to the Sentry™ are protected with surge and EMI filtering to help guarantee uninterrupted service for the life of the sensor. Detailed specifications are included below:

73000 Sentry™ Specifications

Performance

- Visibility Range: 30 m - 16 km (10 m - 10 km optional)
- Extinction Range: 100 – 0.1863 km⁻¹ (300 – 0.30 km⁻¹ optional)
- Accuracy: +/- 10 %
- Time Constant: 60 sec
- Scatter Angle: 42 deg nominal
- Source: 850 nm LED

Power

- AC Version: 100-240 VAC, 50/60 Hz, 24 VA; 75 VA w/ Hood Heaters
- DC Version: 10-36 VDC, 6 VA nominal; 18 VA w/ Hood Heaters

Physical

- Weight: 8 kg (18 lb) nominal
- Dimensions: 889 mm W x 292 mm H x 305 mm D (35 in x 11.5 in x 12 in)
- Mounting: Nominal 40 mm pipe, 48.3 mm OD max (1-1/2 inch IPS pipe, 1.9 inch OD max)
Optional 25 mm pipe, 33 mm OD max (1 inch IPS pipe, 1.3 OD max)

Environmental

- Temperature: -40° to 60° C
- Humidity: 0-100%
- Protection: IP66 (NEMA-4X)

Outputs (Available options are shown)

- 0-10 VDC Option W
- 0-5 VDC Option V
- 4-20 ma single ended Option L
- 4-20 ma isolated Option M
- 1 Control Relay Option C
- Diagnostic Relay Option D
- 2 Control Relays Option E
- 1 Control & 1 Diagnostic Relay Option F
- 2 Control & 1 Diagnostic Relay Option G

The following section describes additional options and accessories that are available for the analog output Sentry™.

1.2.1 Description of Options & Accessories

The model number of the Sentry™ is key to understanding what options are installed in each unit. The model number is found on the sensor label, shown in Figure 1.2.1-1, which is located on the outside of the Main Electronics Enclosure.

The model number is composed of 2 parts. The 5 numeric characters indicate the model (example: 73000) followed by options characters which identify the specific option/s on the unit.



- “D” = mains voltage options
- “W” = analog output options
- “C” = control relay #1

Figure 1.2.1-1 Sensor Label

1.2.1.1 Power Supply Options

The 1st option character group describes the mains voltage options on the Sentry™ as described in Table 1.2.1.1-1.

Table 1.2.1.1-1

When the 1 st character is...	The Mains Voltage is...	Standard or Optional?	Description			
			Voltage Range	Freq	Nominal Power w/o HTRS	Power w/ HTRS ^{Note1}
A	100-240 VAC	Standard	88-264 VAC	47-63 Hz	24 VA	75 VA
D	12 VDC	Optional	10-36 VDC	---	6 VA	18 VA

Note 1 – See Section 1.2.1.3 for information on the external hood heater (HTR) option.

1.2.1.2 Analog Options

The 2nd option character group describes the analog output options on the Sentry™ as described in Table 1.2.1.2-1.

Table 1.2.1.2-1

2 nd Suffix	3 rd Suffix	This output provides....
W		0-10 VDC full scale analog voltage provides the best analog resolution. The output impedance is 50 ohms.
V		0-5 VDC full scale analog voltage provides a reduced analog resolution that may be necessary for some data acquisitions systems. The output impedance is 50 ohms.
L		4-20 ma single-ended - an industry standard method of transmitting the sensor data over long cables. The standard 4-20 ma option uses a single-ended configuration. Operates over total loop resistances of up to 500 ohms.
M		4-20 ma isolated - an industry standard method of transmitting the sensor data over long cables. The isolated 4-20 ma option is for installations prone to severe ground loops. Operates over total loop resistances of up to 500 ohms.
	C	1 Control Relay: Control Relay Output provides user adjustable visibility threshold to activate a relay. This option allows simple control of warning lights, foghorns, gate closures, and other indication devices. The SPDT relays provide normally open (NO) and normally closed (NC) contacts and are rated at 100 VDC, 0.25A.
	D	Diagnostic Relay - Diagnostic Relay Output provides remote indication of sensor status. The relay is continuously activated and will deactivate if a complete power failure occurs or when any of 4 diagnostic tests fail. It checks +5 VDC, +12 VDC, -12 VDC, and transmitter sync for proper operation. The SPDT relays provide normally open (NO) and normally closed (NC) contacts and are rated at 100 VDC, 0.25A.
	E	2 Control Relays
	F	1 Control & 1 Diagnostic Relay
	G	2 Control & 1 Diagnostic Relay



1.2.1.3 Hood Heater (73004 only)

Silicone resistance heaters are installed under each black metal hood that covers the front of the transmitter and receiver heads to prevent blowing snow from clogging the sensor's optical path. Thermostatically controlled to automatically turn on at $\sim 3^{\circ}$ C and off at $\sim 8^{\circ}$ C. With AC powered sensors, each hood heater consumes 25 W of power from a 24 VAC transformer in the Sentry™ Electronics Enclosure. With 12 VDC powered sensors, each hood heater consumes 6 W of power from the 12 VDC input power.

1.2.1.4 Accessories

Several accessories are available with the Sentry™ as described in Table 1.2.1.6-1.

Table 1.2.1.6-1

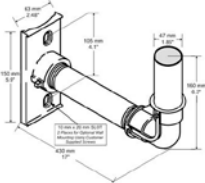
Part Number	Accessory Name	Description
73062	Calibration Fixture	<p>Required for installation and maintenance of the sensor. Provides a traceable calibration of the sensor by scattering a known amount of light from the transmitter to the receiver. One Calibration Fixture can be used on several Sentry™ Visibility Sensors.</p> 
73038	Hood Extension Set	<p>The units slip over the existing sensor hoods to provide additional protection from heavily contaminated air found at some sites. Typical applications include:</p> <ul style="list-style-type: none"> • Road & bridge sites where sensor is <10m from the edge of the roadway • Coastal & maritime areas subject to blowing salt spray • Areas with heavy industrial pollution <p>Includes a set of 2 hood extensions that are easily installed and removable for sensor calibration with a screwdriver.</p> 
74050	Mounting Bracket	<p>Used to mount the Sentry Visibility Sensor with standard 1-1/2" mounting flange. It is designed to provide a durable, vibration-free installation of the Sentry and can be installed against a flat wall, traffic & light poles, or typical ROHN-type tower leg.</p> 
74054	AC Power Cable	<p>Optional North American style 3-conductor, #18 AWG, 3 meter, molded male plug, SJT type, UL & CSA rated, CEE color-codes. Power cables for international orders will be supplied with the appropriate molded plug.</p>
74056	Signal Cable	<p>Optional twisted shielded pair cable, 22 AWG, PVC jacket, where "xx" is the length in meters. Max 15 m (50 ft) recommended.</p>
74055	DC Power Cable	<p>Optional 2-conductor twisted shielded, 20 AWG, PVC jacket, where "xx" is the length in meters. Max 15 m (50 ft) recommended.</p>

1.3 Sensor Description

The Sentry™ is a compact sensor consisting of three (3) major components mounted to a cross arm as shown in Figure 1.3-1. A description of the major components is provided in Table 1.3-1:

Table 1.3-1

Component	Description and Function
TX Head	<p>Externally, the TX Head consists of a weatherproof enclosure to enclose the electrical and optical assemblies and a hood to protect the optics from direct sunlight and precipitation. If the hood heater is ordered, the hood will have a silicone heater adhered to the underside to help prevent snow from blocking the optics.</p> <p>Housed in the TX enclosure are a Transmitter PCB, high power LED, optical lens with heater, and mounting brackets. There are no user serviceable parts in the TX Head.</p> <p style="text-align: center;">WARNING: <i>Opening the TX Head will void the warranty of the sensor.</i></p>
RX Head	<p>Externally, the RX Head consists of a weatherproof enclosure to enclose the electrical and optical assemblies and a hood to protect the optics from direct sunlight and precipitation. If the hood heater is ordered, the hood will have a silicone heater adhered to the underside to help prevent snow from blocking the optics.</p> <p>Housed in the RX enclosure are a Receiver PCB, PIN photodiode, optical lens with heater, and mounting brackets. There are no user serviceable parts in the RX Head.</p> <p style="text-align: center;">WARNING: <i>Opening the RX Head will void the warranty of the sensor.</i></p>
Main Electronics Enclosure	<p>Externally, the Main Enclosure consists of a weatherproof enclosure with hinged door for easy access. A mounting flange is attached to the bottom of the Enclosure for attachment to a support pole of 40 mm dia (1-½" Schedule 40) pipe. A mounting plate is attached to the backside of the Enclosure for use in calibrating the sensor (not shown in Figure 1.3-1). The internal components are discussed in the next section.</p>

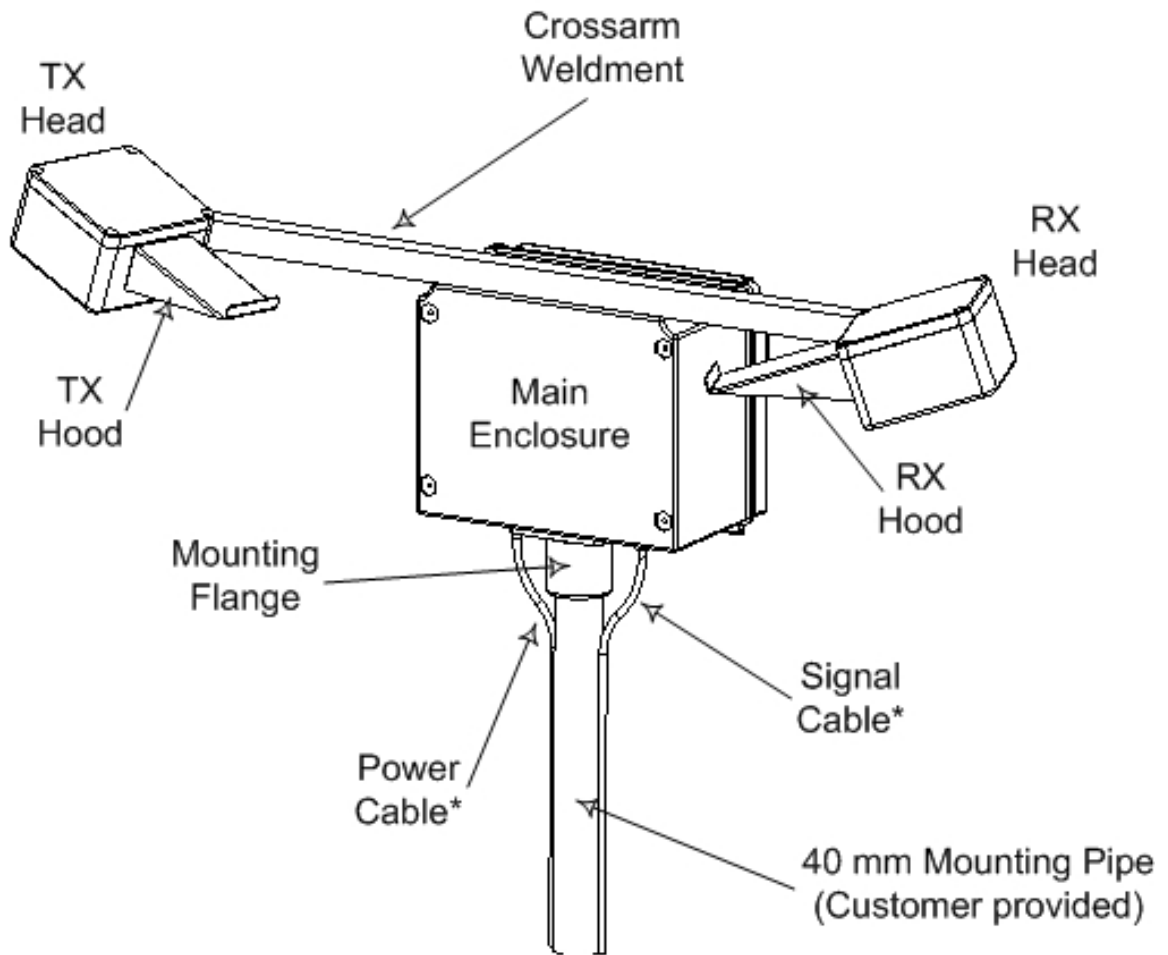

* Optional Items

Figure 1.3-1 Sentry™ Major Components

- AC Power Version – See Table 1.3-2 and Figure 1.3-2 below:

Table 1.3-2

Internal Components of the Main Enclosure	Description and Function
Surge Protection Module 74031-02	Provides AC surge protection, EMI filtering, and short circuit protection. The user makes AC power connections directly to this module using the built-in terminal strip. A red LED on the module is illuminated when the module has failed.
AC Power Supply 73031-02	Universal series switching power supply with short circuit, overload, & over voltage protection. The 50W supply provides +5, +15, and –15 VDC power to the sensor electronics. A green LED indicates power is applied.
AC Transformer 73031-05 (Option)	Provides 24 VAC power to the optional hood heaters. The transformer is only provided if the hood heater option is ordered.
Signal Processor PCB 73020-02 0-10VDC 0-5 VDC 73020L 4-20mA 73020M 4-20mA (Isolated)	<p>This PCB provides signal and DC power distribution to all sensor components. The received signal from the RX PCB is demodulated using the synchronization pulses from the TX PCB. After demodulation, the signal is filtered through a low pass filter, amplified, and scaled to the appropriate level. The output voltage passes through EMI filtering and surge protection before being made available to the user as an analog voltage or current.</p> <p>The Signal processor also contains test points and an array of LEDs (D1) that indicate sensor status. In normal operation, 3 of the LEDs are on continuously, one is off or on based on connection of the optional 4-20 ma current loop, and one LED is blinking approximately once every 2 seconds. Additional information on the diagnostics and test points is contained in Section 5, Maintenance.</p> <p>The analog output voltage or 4-20 ma output current is EMI filtered, surge protected, and available for user connections via an onboard terminal strip, TB1.</p>
3-Relay Output Option PCB 74024C 1 Control Relay 74024D 1 Diag. Relay 74024E 2 Control Relays 74024F 1 Control, 1 Diag 74024G 2 Control, 1 Diag	<p>This PCB plugs into the circuit card guides provided on the Signal Processor PCB and provides up to 3 relay outputs that may be ordered with the sensor. The PCB receives power and signals from the Signal Processor PCB. Two control relays and one diagnostic relay are available. See Section 1.2.1.2 for additional information on the output options.</p>

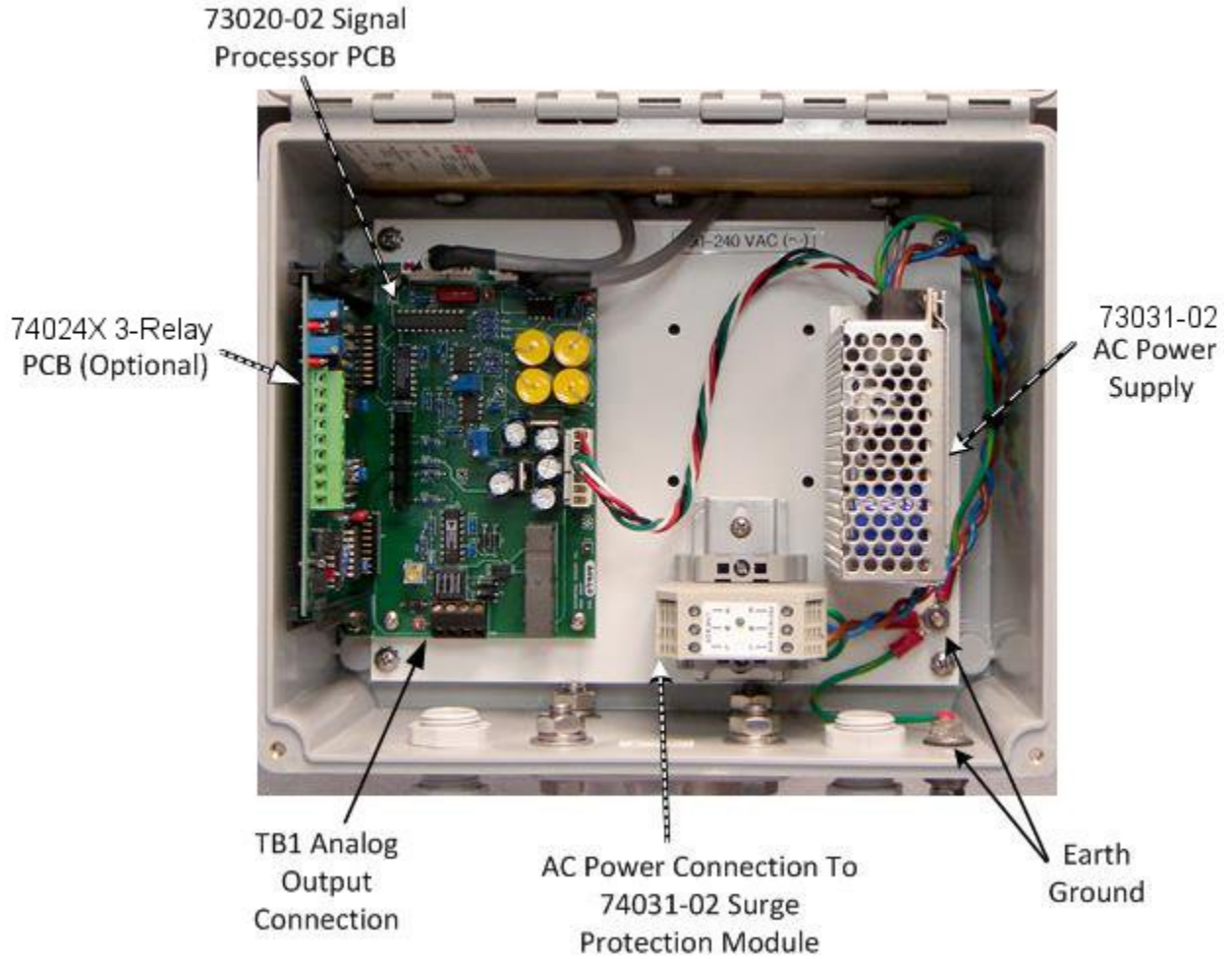

Figure 1.3-2 Main Enclosure Components (AC Power Version)

- DC Power Version – See Table 1.3-3 and Figure 1.3-3 below:

Table 1.3-3

Internal Components of the Main Enclosure	Description and Function
<p>DC Power Supply 73022</p>	<p>The DC/DC Converter Module provides +5, +15, and –15 VDC power to the sensor electronics. Also provides DC surge protection, EMI filtering, and short circuit protection via resettable fuses. The user makes DC power connections directly to this PCB using the built-in terminal board, TB1. The user connects a regulated DC voltage between 10-36 VDC capable of supplying 1A.</p>
<p>Signal Processor PCB</p> <p>73020-02 0-10VDC 0-5 VDC</p> <p>73020L 4-20mA</p> <p>73020M 4-20mA (Isolated)</p>	<p>This PCB provides signal and DC power distribution to all sensor components. The received signal from the RX PCB is demodulated using the synchronization pulses from the TX PCB. After demodulation, the signal is filtered through a low pass filter, amplified, and scaled to the appropriate level. The output voltage passes through EMI filtering and surge protection before being made available to the user as an analog voltage.</p> <p>The Signal processor also contains test points and an array of LEDs (D1) that indicate sensor status. In normal operation, 3 of the LEDs are on continuously, one is off or on based on connection of the optional 4-20 ma current loop, and one LED is blinking approximately once every 2 seconds. Additional information on the diagnostics and test points is contained in Section 5, Maintenance.</p> <p>The analog output voltage or 4-20 ma output current is EMI filtered, surge protected, and available for user connections via an onboard terminal strip, TB1.</p>
<p>3-Relay Output Option PCB</p> <p>74024C 1 Control Relay</p> <p>74024D 1 Diag. Relay</p> <p>74024E 2 Control Relays</p> <p>74024F 1 Control, 1 Diag</p> <p>74024G 2 Control, 1 Diag</p>	<p>This PCB plugs into the circuit card guides provided on the Signal Processor PCB and provides up to 3 relay outputs that may be ordered with the sensor. The PCB receives power and signals from the Signal Processor PCB. Two control relays and one diagnostic relay are available. See Section 1.2.1.3 for additional information on the output options.</p>

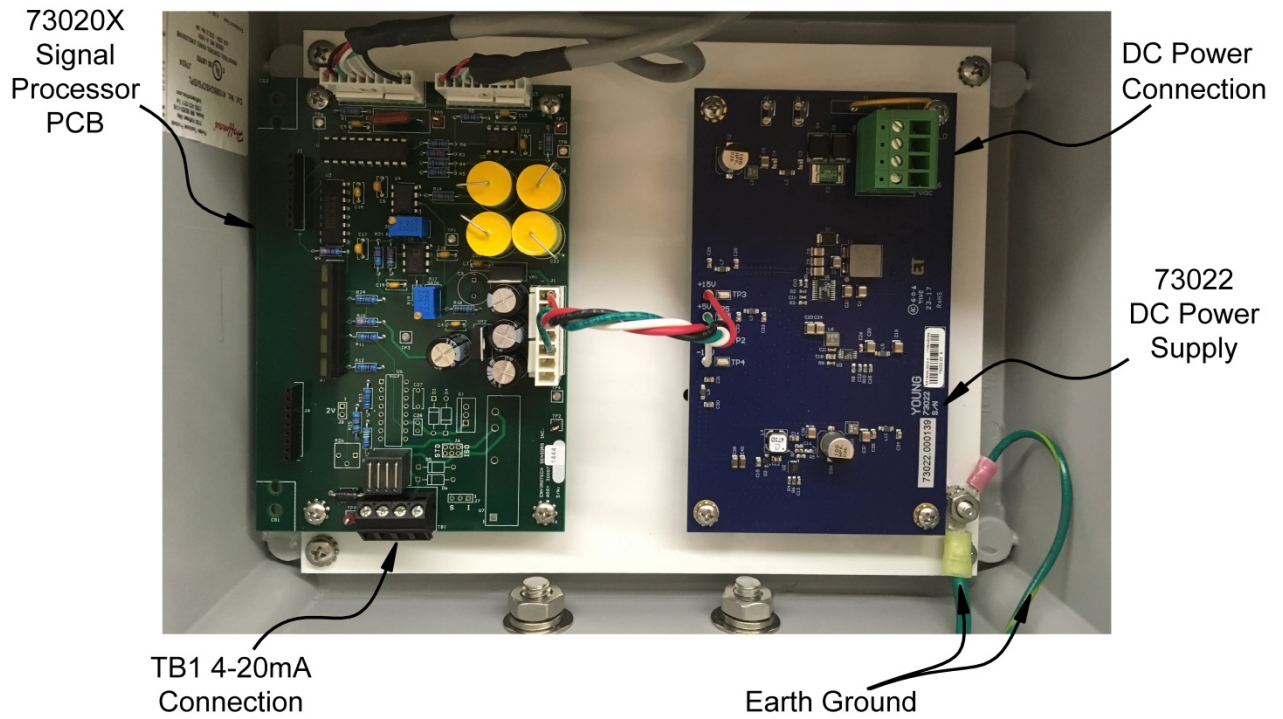

Figure 1.3-3 Main Enclosure Components (DC Power Version)

1.4 Signal Flow

Sentry™ is an electro-optic instrument based on the proven forward scatter technique. The signal flow diagram in Figure 1.4-1 below illustrates the sensor functionality.

The TX Head consists of both electrical and optical subassemblies. The TX PCB contains a frequency source, modulator, power amplifier, phase shifter, temperature compensator, and high power LED. The IR light from an LED is beam formed by an optical lens and projected into the sample volume where it encounters airborne particulate matter. A synchronization pulse is sent from the TX PCB to the Signal Processor PCB to synchronize the demodulation of the received signal. The power and signal cable from the TX Head terminates at J3 on the Signal Processor PCB in the Main Electronics Enclosure.

Light is scattered from the particulate matter in the sample volume in a forward direction and detected by the RX Head. A lens focuses the received IR light onto a sensitive photo detector. The RX PCB provides amplification and bandpass filtering of the received signal before being sent to the Signal Processor PCB. The power and signal cable from the RX Head terminates at J2 on the Signal Processor PCB in the Main Electronics Enclosure.

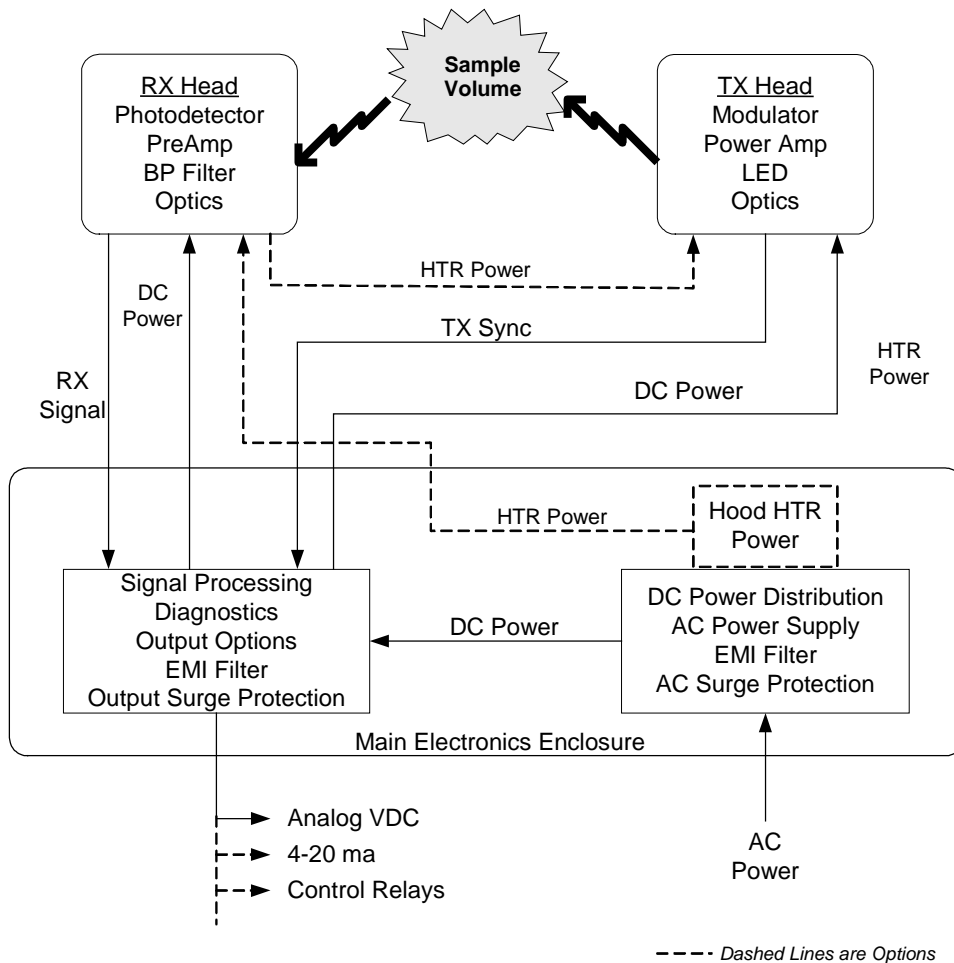

Figure 1.4-1 Sentry™ Signal Flow Diagram

2.0 Installation

2.1 Site Preparation

Site selection and preparation are critical for the successful performance of the Sentry™ Visibility Sensor. If a good location for the sensor is not chosen the sensor is not installed correctly, it will not measure data that is representative of the visibility in the area. *We will be glad to help you with your installation. Call or email any questions & send pictures of proposed locations to discuss your particular application!*

2.1.1 Siting Guidelines

General guidelines for all users:

- Use a sturdy pole or pedestal to reduce vibration.
- Locate the sensor in an area that is representative of the area to be monitored.
- Do not locate the sensor near strobe lights and other modulated light sources.
- Do not locate the sensor in an area that is subject to localized sources of smoke, fog, or mist (air handling exhausts, smoke stacks, etc) unless you are trying to measure the reduction in visibility from these sources.
- The area within 5-6 meters (16-20 feet) of the sensor should be free of all vegetation over 25 cm (10 inch) and well drained.
- Avoid any vertical objects such as hills, walls, or plants within this area.
 - If in path of the TX beam, light may be reflected back into the receiver giving false readings.
 - If in path of RX beam, stray sunlight may be reflected back into the receiver giving false readings
- Mount the sensor so the optics are at least 2.5-3 meters (8-10 feet) above ground or 2.5 meters (8 feet) above the average maximum snow depth, whichever is higher.
- In general, orient the sensor receiver optics so they face within 30 degrees of North in the Northern hemisphere or South in the Southern hemisphere to eliminate direct sunlight contamination. Figure 2.1.1-1 shows the correct orientation in the Northern Hemisphere. In the southern Hemisphere, rotate the sensor 180 degrees. *Note the orientation is not critical; it may be adjusted to fit the needs of the installation.*

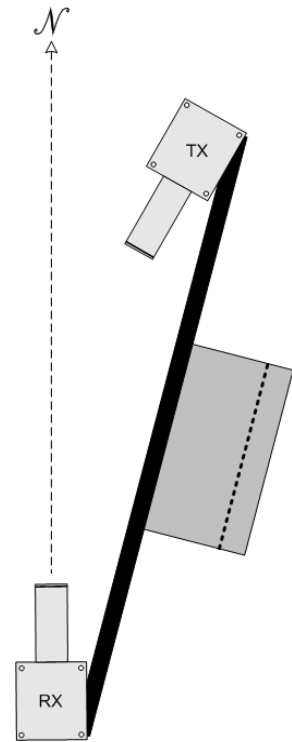

Figure 2.1.1-1 Sensor Orientation

For installations in road weather information systems (RWIS), special conditions may apply:

- Do not locate the sensor on the top of a hill or bottom of a basin unless you wish to measure the visibility in that limited area as may be required for road weather applications.
- Do not locate the sensor too near a roadway to avoid the wet, dirty plumes from passing vehicles that may contaminate the sensor optics.

- If the installation must be near the edge of the road it may be best to orient the sensor parallel to the road with the Main Electronics Enclosure facing the roadway as shown in Figure 2.1.1-2.
- The Federal Highway Administration (FHWA) has established standards for RWIS systems siting. Contact FHWA and request Publication No. FHWA-HOP-05-206 or visit <http://ops.fhwa.dot.gov/publications/ess05/index.htm>.
- The World Meteorological Organization (WMO) has published Report No. 61 - Road Meteorological Observations that also recommends sensor siting. Contact the WMO and request TD 842 (IOM 61) or <http://www.wmo.int/pages/prog/www/IMOP/publication-s-IOM-series.html>.

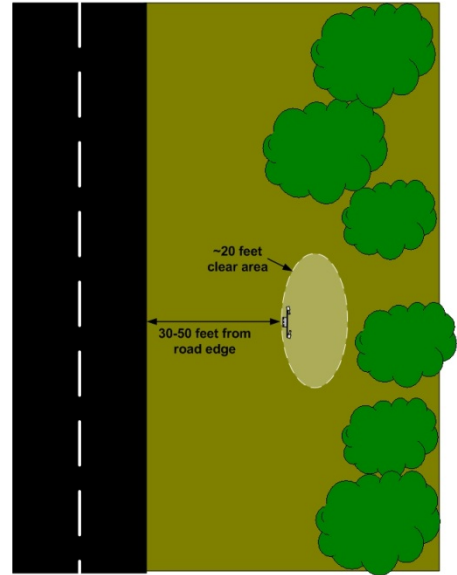

Figure 2.1.1-2 Typical Roadside Installation

For installations in road or rail tunnels, the Tunnel Guidelines document may be requested by sending an E-Mail to: MET.Sales@youngusa.com. It contains information on visibility sensor siting recommendations within the tunnel, specifics about installing the Sentry™, and guidance information about how several agencies around the world are using the data from tunnel mounted visibility sensors. A typical tunnel installation is shown in Figure 2.1.1-3.

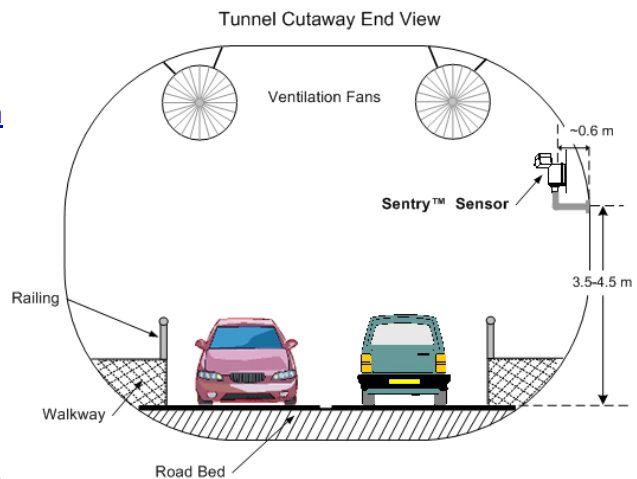

Figure 2.1.1-3 Typical Tunnel Installation

For installations on offshore platforms, the EEx Sentry Siting document may be requested by sending an E-Mail to: MET.Sales@youngusa.com. It contains specific information for siting & installing the Sentry™ on offshore platforms to ensure proper operation in that critical environment.

For installations at airports the user is encouraged to contact the appropriate regulating agency(ies) to ensure compliance with aviation requirements:

- U.S.A. – Office of the Federal Coordinator for Meteorology at 301.427.2002 (Silver Spring, Maryland) for a copy of “Federal Standard for Siting Meteorological Sensors at Airports, OFCM, FCM-S4-1994” and other related documents. or visit <http://www.ofcm.gov/siting/text/a-cover.htm>.

- International – International Civil Aviation Organization at 514.954.8022 (Montreal, Quebec Canada) for a copy of “Manual of Aeronautical Meteorological Practice” and other related documents. Or visit <http://www.icao.int/icao/en/sales.htm>.

2.1.2 Site Preparation

The selected site must be prepared in accordance with local construction codes and therefore the information provided in this section is for guidance only. The Sentry™ is typically installed in one of two ways; attached to an existing structure such as a meteorological tower or as a stand-alone installation. In either case, provisions must be made for physically supporting the structure, earth grounding, power, and signal wiring.

- Support Structure - If the sensor is to be installed as a stand-alone instrument, prepare a concrete footer as shown in Figure 2.1.2-1. It is recommended that depth of the concrete footer is below the frost line to avoid heaving. When preparing for the concrete footer also plan for earth grounding, power wiring, and signal wiring.

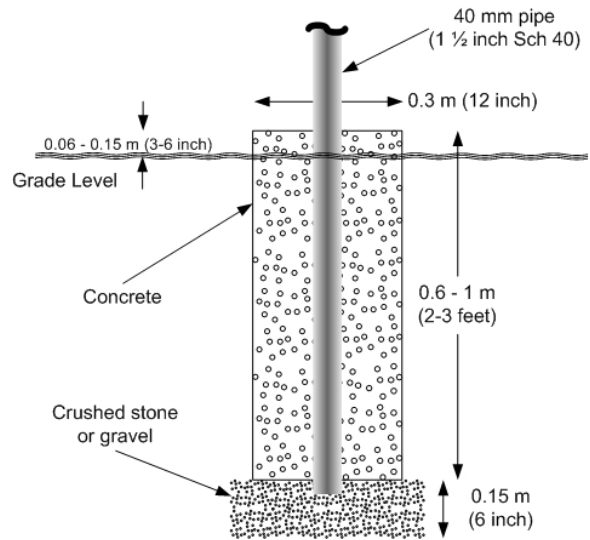

Figure 2.1.2-1 Site Preparation – Concrete Footer

- The Sentry™ may also be installed on an existing structure such as a traffic pole or triangular tower using the optional 74050 Mounting Bracket. A customer provided boom arm structure may also be assembled from 1 ½ inch schedule 40 pipe & fittings as shown in Figure 2.1.2-2. *Check your sensor model number - if it ends in “P”, your sensor is equipped with a 1” nominal pipe flange and you must use 1-inch pipe for the mounting arm.* Otherwise, use 1-1/2 pipe. The boom arm structure should be attached to the side of the triangulate tower with U-bolts or similar hardware. When selecting which side of the tower to use, make certain that the sensor sample volume is facing away from the tower and not over the boom arm while still aligning the receiver optics facing in a northerly direction or parallel with the roadway.

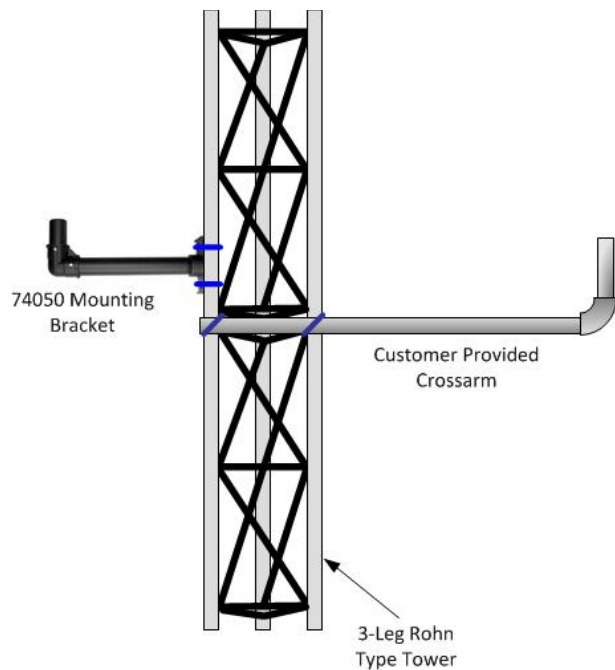

Figure 2.1.2-2 Site Preparation – Mounting Brackets

- Earth Grounding – The Sentry™ must be grounded to an approved earth terminal for electrical safety and for the built-in lightning protection circuitry to work properly. This wiring is in addition to the “ground” wire that is part of the AC power wiring. Additional information on earth grounding is found in Section 2.3.3.
- Power – The Sentry™ requires a source of single phase AC power (unless the 12 VDC option was ordered) at 1 A current. Consideration should be made to add power and signal junction boxes near the sensor during the construction phase. Additional information on AC wiring is found in Section 2.3.1.
- Signal Wiring – The rule of thumb is that the shorter the signal wire, the better. R.M. Young Company recommends that signal wires be <15 m (<50 ft) and 22 AWG (0.326 mm²) or larger wire gauge. Exceptions to this rule are made for the optional 4-20 ma current loop output option and the control relay option where the cable may be much longer.

2.2 Mechanical Installation

Once the site preparation is complete, physically installing the Sentry™ is simple. Follow these steps to complete the mechanical installation as shown in Figure 2.2-1.

When unpacking the sensor, carefully remove the packing material and lift the sensor out of the shipping carton. If the sensor must be laid down, lay it flat with the front door of the Main Electronics Enclosure down to avoid any damage to the sensor heads or hoods.

Equipment required:

- *9/16” wrench, 9/16” nut driver, or adjustable wrench*

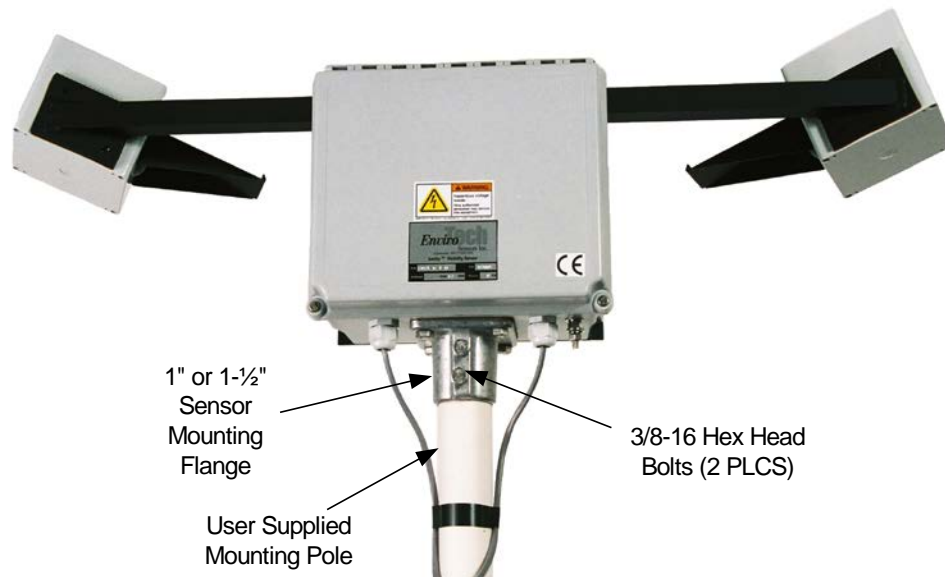

Figure 2.2-1 Mechanical Installation

1. Remove the sensor from the shipping carton and inspect for obvious damage.
2. Lift the sensor over the mounting pole and carefully lower it to engage the flange.
3. Rotate the sensor per the instructions in Section 2.1.1 above.
4. Tighten the two (2) 3/8-16 hex head bolts in the flange to secure the sensor to the pole.
5. Go to Section 2.3 to connect the signal wiring.

2.3 Signal Wiring

The signal wiring depends on the output options that are supplied with the sensor. Read the model number label on the outside of the Main Electronics Enclosure. The suffixes after the five numerical digits indicate the installed options as follows:

Table 2.3-1

The suffix is	Then your output is	See section
W	0-10 VDC analog	2.3.1
V	0-5 VDC analog	2.3.1
L	4-20 ma, single ended	2.3.2
M	4-20 ma, isolated	2.3.2
C	1 Control Relay	2.3.3
D	Diagnostic Relay	2.3.3
E	2 Control Relays	2.3.3
F	1 Control, 1 Diagnostic Relay	2.3.3
G	2 Control, 1 Diagnostic Relay	2.3.3

2.3.1 Analog Voltage Output Connection

1. Open the Main Electronics Enclosure by loosening the 2 captive screws on the bottom corners of the enclosure.
2. Loosen the cord grip on the lower left bottom of the Main Electronics Enclosure.
3. Feed a twisted, shielded pair cable into the enclosure through the cord grip. 22 AWG (0.326 mm²) or larger wire is recommended. The maximum cable run should be <15 m (50 ft).
4. Strip ~6 mm (1/4") of insulation from each of the two conductors and connect them to Pins 1 (+) and 2 (-) of TB1 as shown in Table 2.3.1-1 and Figure 2.3.1-1.

Table 2.3.1-1

TB1 Terminal	Function
1	+ VDC Out
2	VDC Return

5. Tighten the cord grip to secure the signal cable.
6. Connect the other end of the cable to the user's data acquisition equipment per the manufacturers' instructions. To reduce noise on the cable, connect the cable shield to either signal ground or earth ground at the data acquisition system as required.
7. Go to Section 2.4 for electrical power wiring instructions.

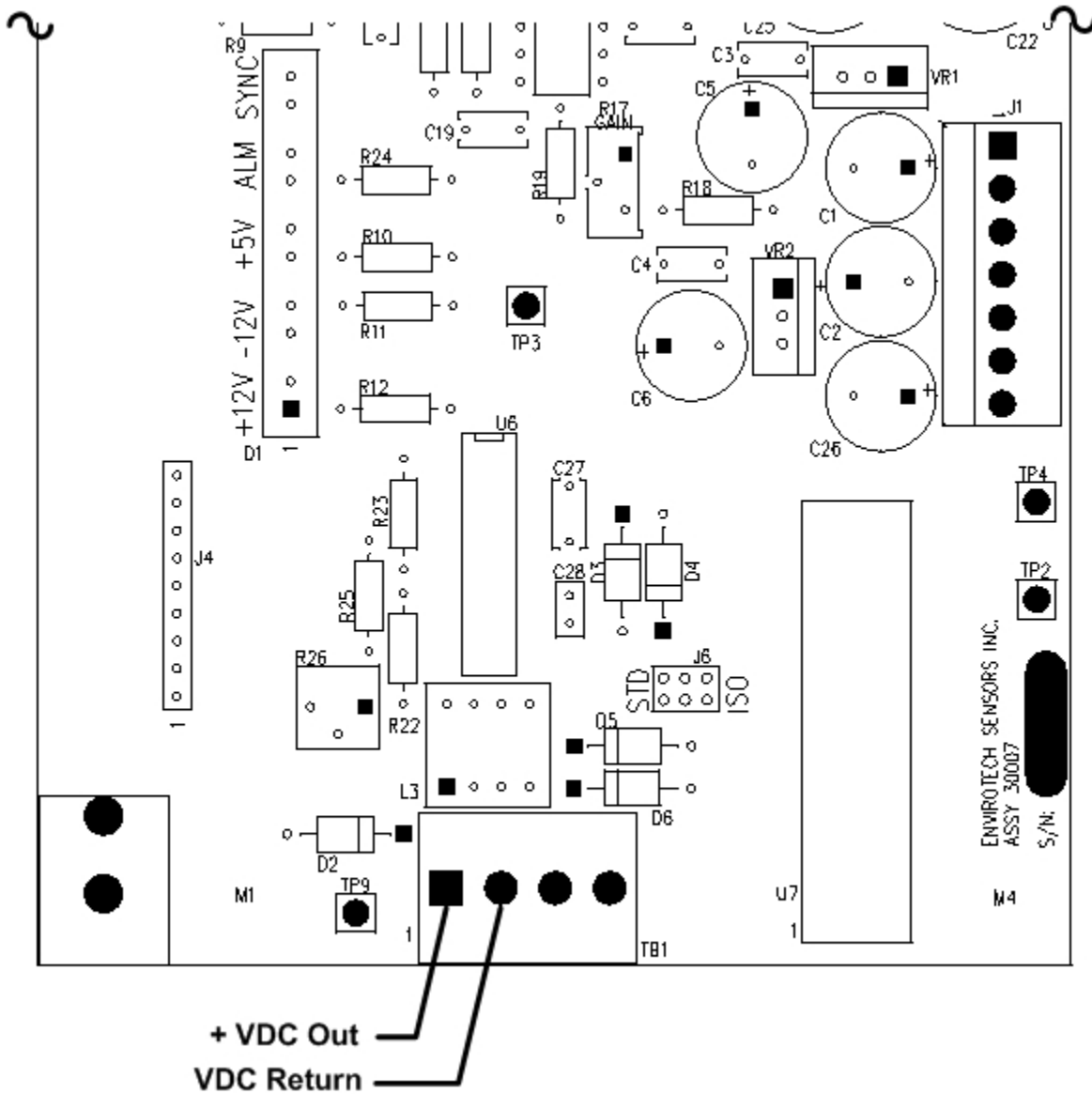

Figure 2.3.1-1 Analog Output Voltage Connections

2.3.2 4-20 ma Current Loop Output Connection

The Sentry™ 4-20 ma output options are part of the Signal Processor PCB in the Main Electronics Enclosure. The PCB is factory configured for either single-ended (-L) or isolated (-M) 4-20 ma depending on the option ordered. User connections are made to TB1 of the Signal Processor PCB.

1. Loosen the cord grip on the lower left bottom of the Main Electronics Enclosure.
2. Feed a twisted, shielded pair cable into the enclosure through the cord grip. 22 AWG (0.326 mm²) or larger wire is recommended. The cable run may be as long as necessary provided the total resistance of the entire loop including outgoing wire, customer data acquisition system resistance, and return wire is < 500 ohms.
3. Strip ~6 mm (1/4") of insulation from each of the two conductors and connect them to TB1 using the information in Table 2.3.2-1 and Figure 2.3.2-1.

Table 2.3.2-1

TB1 Terminal	Function
3	+ ma Out
4	- ma Return

4. Tighten the cord grip to secure the signal cable.
5. Connect the other end of the cable to the users' data acquisition equipment per the manufacturers' instructions. To reduce noise on the cable, connect the cable shield to either signal ground or earth ground at the data acquisition system as required.
6. Go to Section 2.4 for electrical power wiring instructions.

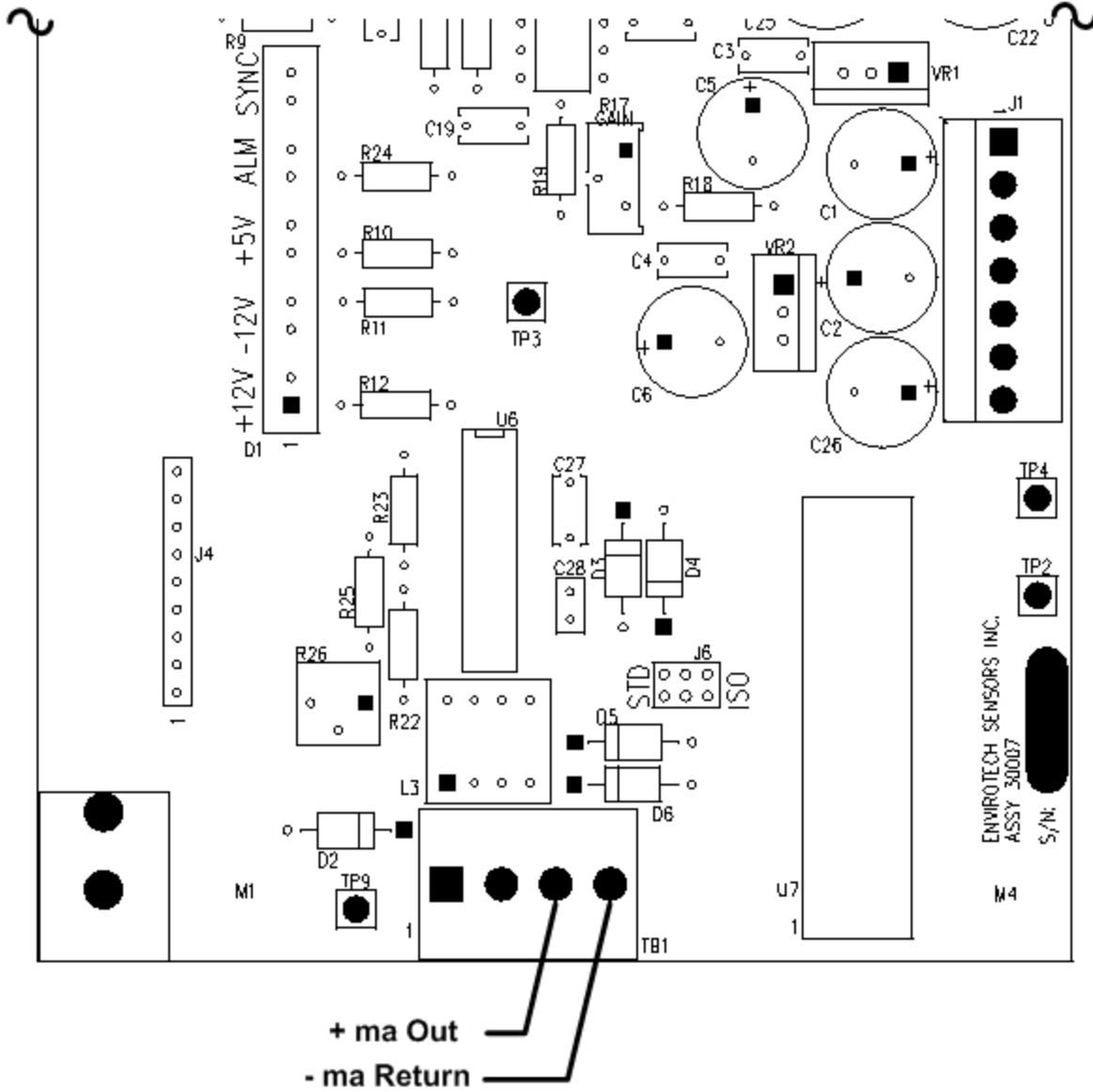

Figure 2.3.2-1 4-20 ma Current Loop Output Signal Connections

2.3.3 3-Relay Output Connection for 74024X

The Sentry™ relay options are part of an auxiliary PCB that plugs into the Signal Processor PCB in the Main Electronics Enclosure. User connections are made to TB1 of the 74024X 3-Relay PCB depending on what options were ordered.

1. Loosen the cord grip on the lower left bottom of the Main Electronics Enclosure.
2. Depending on the number of relays to be wired, feed a 1, 2, or 3-twisted, shielded pair cable into the enclosure through the cord grip. 22 AWG (0.326 mm²) or larger wire is recommended. The cable run should be as short as possible.
3. For the control relay #1 option (Sensor 73000xxC), strip ~6 mm (1/4") of insulation from each of the conductors and connect them to TB1 using the information in Table 2.3.3-1 and Figure 2.3.3-1. Note that the terminals marked with a "C" prefix refer to the control relay output.

Table 2.3.3-1

TB1 Terminal	Function
CNO1	Normally Open (NO)
CCOM1	Common
CNC1	Normally Closed (NC)

4. For the control relay #2 option (Sensor 73000xxE), strip ~6 mm (1/4") of insulation from each of the conductors and connect them to TB1 using the information in Table 2.3.3-2 and Figure 2.3.3-1. Note that the terminals marked with a "C" prefix refer to the control relay output.

Table 2.3.3-2

TB1 Terminal	Function
CNO2	Normally Open (NO)
CCOM2	Common
CNC2	Normally Closed (NC)

5. For the diagnostic relay option (Sensor 73000xxD), strip ~6 mm (1/4") of insulation from each of the conductors and connect them to TB1 using the information in Table 2.3.3-3 and Figure 2.3.3-1. Note that the terminals marked with a "D" prefix refer to the diagnostic relay output.

Table 2.3.3-3

TB1 Terminal	Function
DNO	Normally Open (NO)
DCOM	Common
DNC	Normally Closed (NC)

6. Tighten the cord grip to secure the signal cable.
7. Connect the other end of the cable to the users data acquisition equipment per the manufacturers instructions. To reduce noise on the cable, connect the cable shield to either signal ground or earth ground at the data acquisition system.
8. Go to Section 2.4 for electrical power wiring instructions.

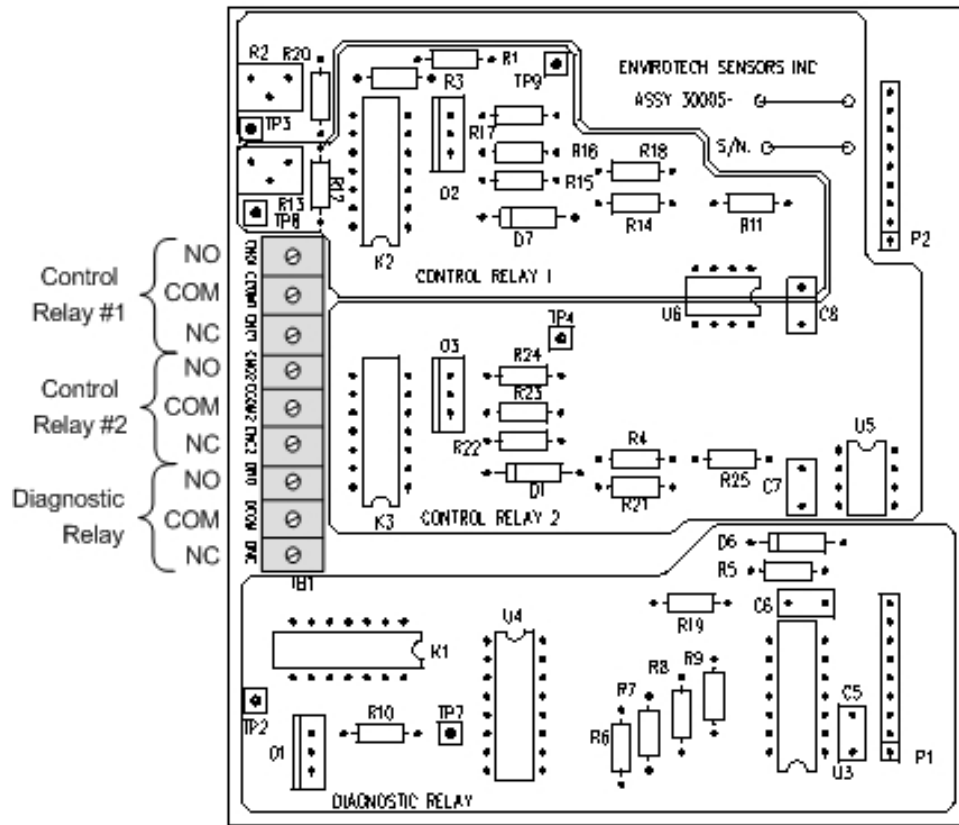

Figure 2.3.3-1 3-Relay Output Signal Connections

2.4 Electrical Power Installation

The most important step in connecting power to the Sentry™ is to make sure only authorized personnel make the AC connections. Read the information in Section 2 of this User's Guide completely before proceeding. Remember that local electrical codes supersede the recommendations provided herein. If you have a question, call R.M. Young Company at 231-946-3980.



The second step in connecting power to the Sentry™ is to make sure the correct mains voltage is used. Read the product label on the outside of the Main Electronics Enclosure door and compare the part number in Table 2.4-1 as follows:

Table 2.4-1

If your is	Then your mains is	See section
73000A	110-240 VAC, 50/60 Hz	2.4.1
73000D	10-36 VDC	2.4.2

For protection from lightning and other electrical surges, the sensor should be grounded to a rod driven into the ground adjacent to the sensor per Section 2.4.3.

Equipment required:

- *¼ inch straight blade screwdriver*
- *Small screwdriver*
- *Wire cutters*
- *Wire strippers*
- *Adjustable wrench*
- *7/16 inch wrench, 7/16 inch nut driver, or adjustable wrench*

2.4.1 AC Power Connections

1. Select an approved AC power cord with 3-wires that includes a ground and wire gauge of 18 AWG (0.902 mm²) or larger wire is recommended. The cable run should be as short as possible.
2. Loosen the cord grip on the lower right bottom of the Main Electronics Enclosure.
3. Feed the power cable into the enclosure through the cord grip. Strip ~6 mm (1/4") of insulation from each of the three conductors and connect them to the line (left) side of the Surge Protection Module as shown per Table 2.4.1-1 and in Figure 2.4.1-1.

Table 2.4.1-1

International (ICC) Colors	North American (NA) Colors	Surge Module Terminal
Green/Yellow	Green	E (earth ground)
Blue	White	N (neutral)
Brown	Black	L (line)

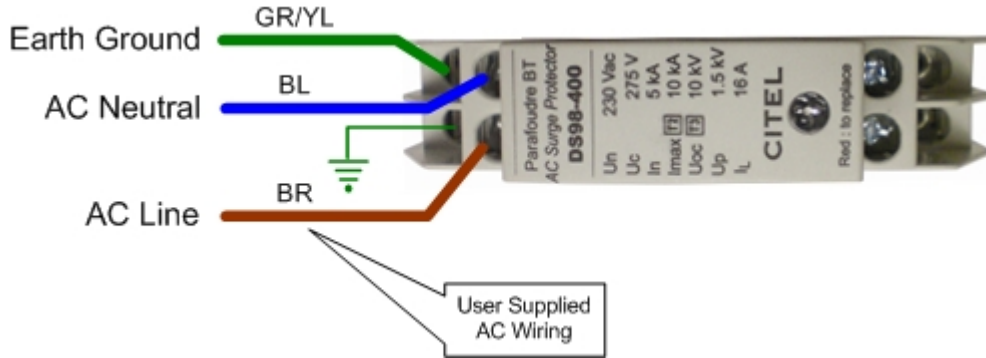

Figure 2.4.1-1 User AC Power Wiring

4. Tighten the cord grip to secure the power cord.
5. Go to Section 2.4.3 for earth grounding the Sentry™.

2.4.2 DC Power Connections (Optional)

1. A regulated DC power supply with a rating of 1 A minimum is recommended to power the Sentry™. A properly sized battery backed solar powered system may also be used.
2. Loosen the cord grip on the lower right bottom of the Main Electronics Enclosure.
3. Feed a 2 or 3-conductor power cable into the enclosure through the cord grip. 18 AWG (0.823 mm²) or larger wire is recommended.
4. Strip ~6 mm (1/4") of insulation from each of the conductors and connect them to TB1 of the 73022 DC Power PCB Assy as shown per Table 2.4.2-1 and in Figure 2.4.2-1.
5. Tighten the cord grip to secure the power cord.
6. Go to Section 2.4.3 for earth grounding the Sentry™.

Table 2.4.2-1

TB1	DC Power Version	User Wire Color
1	+10-36 VDC	
2	VDC Common	
3	(No Connection)	
4	Earth Ground	GR/YL to Ground Stud

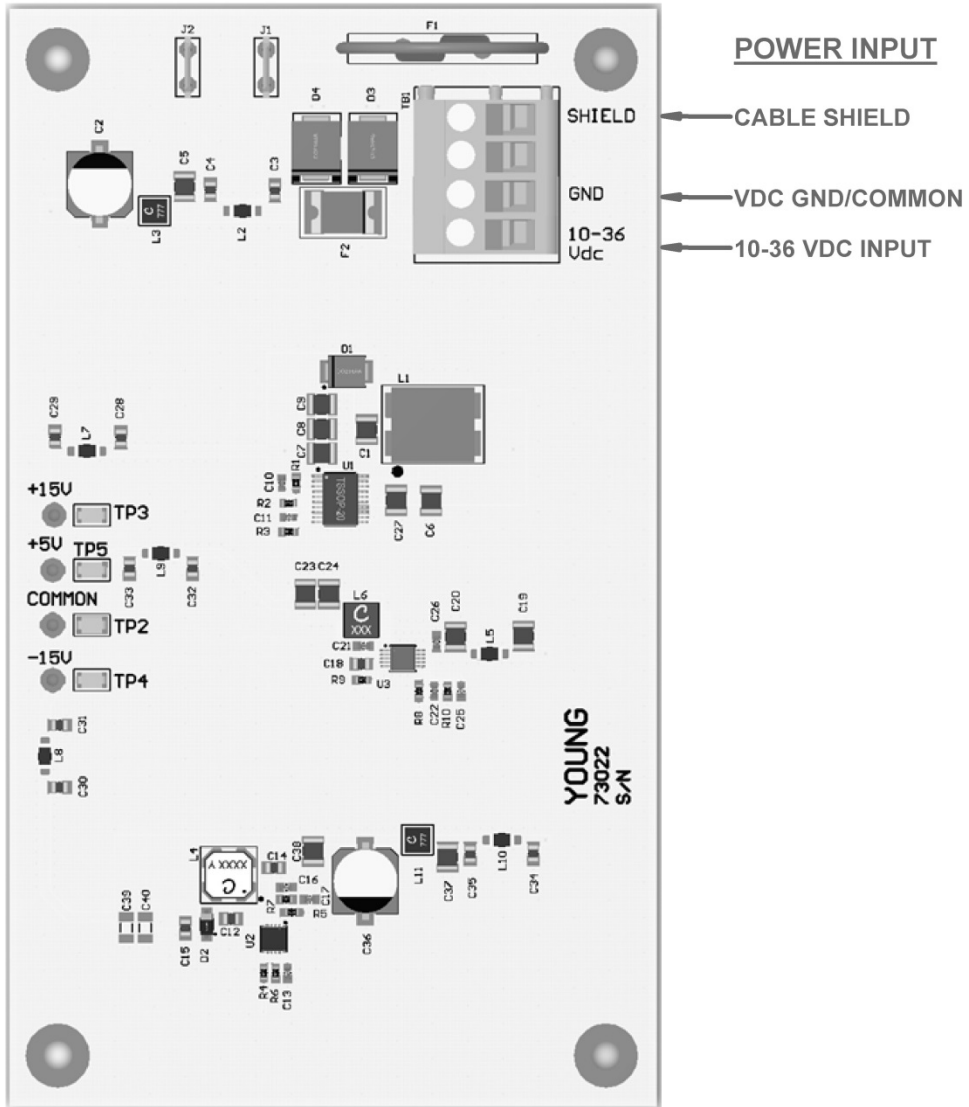

Figure 2.4.2-1 User DC Power Wiring

2.4.3 Earth Grounding Connections

Earth grounding is required to insure that the surge protection devices in the sensor work properly. In addition, it also provides a safety ground that may be required by local electrical codes. A ¼-20 threaded stud is provided on the bottom of the Sentry™ Main Electronics Enclosure for this purpose. Refer to Figure 2.4.3-1 for an illustration of proper grounding.

1. Drive an 8-10 foot long copper clad ground rod into the earth, adjacent to the sensor support structure.
2. Connect a customer supplied large gauge copper wire (#4 AWG (21 mm²) typical) from the ¼-20 ground stud on the bottom of the Sentry™ enclosure to the ground rod using the shortest length of wire. Do not over tighten the ¼-20 nut.

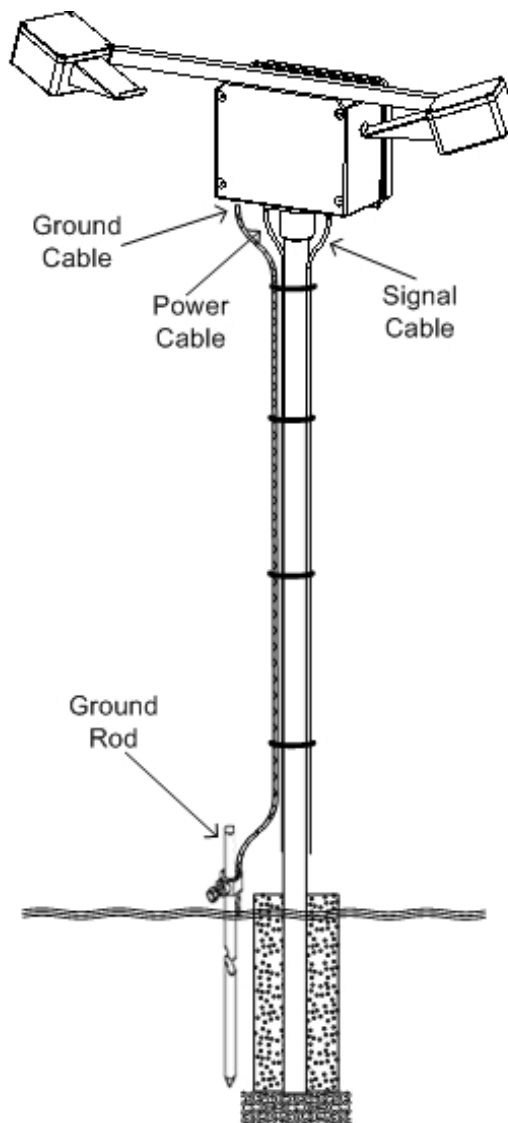

Figure 2.4.3-1 Earth Grounding

3.0 Data Interpretation and Operation

Interpretation of the data depends on which visibility range and output option was ordered with your sensor. Read the product label on the outside of the Main Electronics Enclosure door and compare the part number suffix as follows:

Table 3.0-1

If your is	Then your output is	See section
73000xx <u>W</u>	0-10 VDC analog	3.1
73000xx <u>V</u>	0-5 VDC analog	3.1
73000xx <u>L</u>	4-20 ma, single ended	3.2
73000xx <u>M</u>	4-20 ma, isolated	3.2

3.1 Analog Voltage Output

The standard Sentry™ visibility measurement range is 30m - 16 km with an output voltage range of 0-10 VDC or 0-5 VDC as optional. The alternate Sentry™ visibility measurement range is 10m - 10 km with an output voltage range of 0-10 VDC or 0-5 VDC as optional. Unless special ordered, the Sentry is supplied with the 16 km visibility range. On special order, the Sentry is supplied with a 10 km range and this will be noted on the inside of the Main Electronics Enclosure. The sensor analog output voltage must be converted to extinction coefficient, σ , or visibility, MOR, in the appropriate units of measure. Most users should convert directly from voltage to visibility using one of the formulas in Table 3.1-1.

Table 3.1-1

Visibility Units of Measure	30m - 16 km Range		10m - 10 km Range	
	0-10 VDC Output	0-5 VDC Output	0-10 VDC Output	0-5 VDC Output
Kilometers (km)	0.300 / sensor output (VDC)	0.150 / sensor output (VDC)	0.100 / sensor output (VDC)	0.050 / sensor output (VDC)
Meters (m)	300 / sensor output (VDC)	150 / sensor output (VDC)	100 / sensor output (VDC)	50 / sensor output (VDC)
Miles (mi)	0.1864 / sensor output (VDC)	0.0932 / sensor output (VDC)	0.06213 / sensor output (VDC)	0.0311 / sensor output (VDC)
Feet (ft)	984 / sensor output (VDC)	492 / sensor output (VDC)	328 / sensor output (VDC)	164 / sensor output (VDC)

--- Note ---

It is very important to use the correct formula depending on what sensor visibility range and output voltage range was ordered.

Alternately, the sensor output voltage may be converted to extinction coefficient, σ , as follows:

$$\sigma \text{ (km}^{-1}\text{)} = K \cdot \text{sensor output voltage (VDC)}$$

where “K” is the calibration constant listed in Table 3.1-2.

Then the extinction coefficient can be converted to visibility using:

$$\text{MOR} = 3/\sigma$$

where MOR is the meteorological optical range (visibility) and σ is the extinction coefficient.

--- Note ---

Remember that since the unit of measure of extinction coefficient is km^{-1} , the calculated unit of measure of visibility is therefore kilometers. To obtain the visibility in statute miles, multiply the visibility in kilometers by 0.6412.

Table 3.1-2

Visibility Range	Output Range	Calibration Constant (K)	Lower Voltage Limit
30m - 16 km	0-10 VDC	10	0.01863 VDC
30m - 16 km	0-5 VDC	20	0.00932 VDC
10m - 10 km	0-10 VDC	30	0.010 VDC
10m - 10 km	0-5 VDC	60	0.005 VDC

- Note -

The following paragraph describes the data processing algorithm that must be followed to insure proper operation of the Sentry™ over its operating range!

A simplified data processing algorithm is provided as guidance:

- Read sensor output voltage every few seconds
- Limit the sensor output to the full-scale range using an “IF, THEN” type logic statement. “IF” the sensor output voltage is “<” the value shown, “THEN” set the sensor voltage to the value shown in Table 3.1-2 above. Else, set the voltage reading to actual reading.
- Convert to visibility in correct units of measure using formulas provided
- Compute running average of 3-5 minutes
- Archive averaged data once per minute

As an example:

1. If the sensor voltage = 0.0150 VDC for a 16 km visibility range with 0-10 VDC analog output (0.0150 VDC < 0.01863 VDC) then set the voltage to 0.01863 VDC (10 miles or 16 km).

2. If the sensor voltage = 0.0220 VDC for a 16 km visibility range with 0-10 VDC analog output (0.0220 VDC > 0.01863 VDC) then set the value to the measured voltage of 0.0220 VDC and calculate the visibility as $0.1864 / 0.0220 = 8.47$ miles or 13.9 km.

Table 3.1-3 below shows the relationship between sensor voltage, extinction coefficient (EXCO), and equivalent MOR (visibility) in kilometers, meters, statute miles, and feet for the standard 30m - 16 km visibility range with 0-10 VDC and 0-5 VDC voltage outputs. Table 3.1-4 repeats this information for the optional 10m - 10 km visibility range.

- Note -

The Sentry output voltage may saturate at >10 VDC if there is too much scattering of light into the receiver. This may occur with either the 0-5 VDC or 0-10 VDC analog output options.

Table 3.1-3

SENTRY™ VISIBILITY SENSOR OUTPUT CURVE
Standard 30m - 16 Km Visibility Range

Sentry™ Voltage	10 VDC Full Scale Output					5 VDC Full Scale Output				
	EXCO (km-1)	MOR (km)	MOR (m)	MOR (mi)	MOR (ft)	EXCO (km-1)	MOR (km)	MOR (m)	MOR (mi)	MOR (ft)
10.0000	100.000	0.0300	30	0.019	98					
9.0000	90.000	0.0333	33	0.021	109					
8.0000	80.000	0.0375	38	0.023	123					
7.0000	70.000	0.0429	43	0.027	141					
6.0000	60.000	0.0500	50	0.031	164					
5.0000	50.000	0.0600	60	0.037	197	100.000	0.0300	30	0.019	98
4.0000	40.000	0.0750	75	0.047	246	80.000	0.0375	38	0.023	123
3.0000	30.000	0.1000	100	0.062	328	60.000	0.0500	50	0.031	164
2.0000	20.000	0.1500	150	0.093	492	40.000	0.0750	75	0.047	246
1.0000	10.000	0.3000	300	0.186	984	20.000	0.1500	150	0.093	492
0.7500	7.500	0.4000	400	0.249	1312	15.000	0.2000	200	0.124	656
0.5000	5.000	0.6000	600	0.373	1968	10.000	0.3000	300	0.186	984
0.2500	2.500	1.2000	1200	0.746	3937	5.000	0.6000	600	0.373	1968
0.1000	1.000	3.0000	3000	1.864	9842	2.000	1.5000	1500	0.932	4921
0.0500	0.500	6.0000	6000	3.728	19685	1.000	3.0000	3000	1.864	9842
0.0400	0.400	7.5000	7500	4.661	24606	0.800	3.7500	3750	2.330	12303
0.0300	0.300	10.0000	10000	6.214	32808	0.600	5.0000	5000	3.107	16404
0.0250	0.250	12.0000	12000	7.457	39370	0.500	6.0000	6000	3.728	19685
0.0200	0.200	15.0000	15000	9.321	49212	0.400	7.5000	7500	4.661	24606
0.0186	0.186	16.1031	16103	10.006	52831	0.373	8.0515	8052	5.003	26415
0.0150						0.300	10.0000	10000	6.214	32808
0.0125						0.250	12.0000	12000	7.457	39370
0.00932						0.186	16.0944	16094	10.001	52803

Table 3.1-4

SENTRY™ VISIBILITY SENSOR OUTPUT CURVE
Optional 10m - 10 Km Visibility Range

Sentry™ Voltage	10 VDC Full Scale Output					5 VDC Full scale Output				
	EXCO (km-1)	MOR (km)	MOR (m)	MOR (mi)	MOR (ft)	EXCO (km-1)	MOR (km)	MOR (m)	MOR (mi)	MOR (ft)
10.0000	300.000	0.0100	10	0.006	33					
9.0000	270.000	0.0111	11	0.007	36					
8.0000	240.000	0.0125	13	0.008	41					
7.0000	210.000	0.0143	14	0.009	47					
6.0000	180.000	0.0167	17	0.010	55					
5.0000	150.000	0.0200	20	0.012	66	300.000	0.0100	10	0.006	33
4.0000	120.000	0.0250	25	0.016	82	240.000	0.0125	13	0.008	41
3.0000	90.000	0.0333	33	0.021	109	180.000	0.0167	17	0.010	55
2.0000	60.000	0.0500	50	0.031	164	120.000	0.0250	25	0.016	82
1.0000	30.000	0.1000	100	0.062	328	60.000	0.0500	50	0.031	164
0.7500	22.500	0.1333	133	0.083	437	45.000	0.0667	67	0.041	219
0.5000	15.000	0.2000	200	0.124	656	30.000	0.1000	100	0.062	328
0.2500	7.500	0.4000	400	0.249	1312	15.000	0.2000	200	0.124	656
0.1000	3.000	1.0000	1000	0.621	3281	6.000	0.5000	500	0.311	1640
0.0500	1.500	2.0000	2000	1.243	6562	3.000	1.0000	1000	0.621	3281
0.0400	1.200	2.5000	2500	1.554	8202	2.400	1.2500	1250	0.777	4101
0.0300	0.900	3.3333	3333	2.071	10936	1.800	1.6667	1667	1.036	5468
0.0250	0.750	4.0000	4000	2.486	13123	1.500	2.0000	2000	1.243	6562
0.0200	0.600	5.0000	5000	3.107	16404	1.200	2.5000	2500	1.554	8202
0.0186	0.559	5.3677	5368	3.335	17610	1.118	2.6838	2684	1.668	8805
0.0150	0.450	6.6667	6667	4.143	21872	0.900	3.3333	3333	2.071	10936
0.0125	0.375	8.0000	8000	4.971	26246	0.750	4.0000	4000	2.486	13123
0.00932	0.280	10.7296	10730	6.667	35202	0.559	5.3648	5365	3.334	17601
0.01000	0.300	10.0000	10000	6.214	32808	0.600	5.0000	5000	3.107	16404
0.0080						0.480	6.2500	6250	3.884	20505
0.0060						0.360	8.3333	8333	5.178	27340
0.0050						0.300	10.0000	10000	6.214	32808

3.2 4-20 ma Current Loop Output (Optional)

The operation of the Sentry™ is the same for both the single ended 4-20 ma (Sensor 73000-x-L) and the isolated 4-20 ma (Sensor 73000-x-M) options.

The sensor current output (ma) must be converted to extinction coefficient, σ or visibility, MOR, in the appropriate units of measure. Most users should convert directly from current to visibility using one of the formulas in Table 3.2-1.

Table 3.2-1.

	30m - 16 km Range	10m - 10 km Range
Visibility Units of Measure	4-20 ma Output	4-20 ma Output
Kilometers (km)	0.480 / (ma output – 4 ma)	0.160 / (ma output – 4 ma)
Meters (m)	480 / (ma output – 4 ma)	160 / (ma output – 4 ma)
Miles (mi)	0.298 / (ma output – 4 ma)	0.0993 / (ma output – 4 ma)
Feet (ft)	1568 / (ma output – 4 ma)	522.7 / (ma output – 4 ma)

--- Note ---

It is very important to use the correct formula depending on what sensor visibility range and output voltage range was ordered.

Alternately, the sensor output current may be converted to extinction coefficient, σ , as follows:

$$\sigma \text{ (km}^{-1}\text{)} = K \cdot (\text{ma output} - 4 \text{ ma}) / 1.6$$

where “K” is the calibration constant listed in Table 3.2-2.

Then the extinction coefficient can be converted to visibility using:

$$\text{MOR} = 3/\sigma$$

where MOR is the meteorological optical range (visibility) and σ is the extinction coefficient.

- Note -

Remember that since the unit of measure of extinction coefficient is km^{-1} , the calculated unit of measure of visibility is therefore kilometers. To obtain the visibility in statute miles, multiply the visibility in kilometers by 0.6412.

Table 3.2-2

Visibility Range	Output Range	Calibration Constant (K)	Lower Current Limit
30m - 16 km	4-20 ma	10	4.030 ma
10m - 10 km	4-20 ma	30	4.016 ma

As shown in Figure 5.4.1-1, a green LED, D4, is provided on the Signal Processor PCB that provides an alarm indication of whether the 4-20 ma loop is connected and within voltage limits. In normal operation with a complete connection to the user's data acquisition equipment, the ALM LED should be OFF. If the LED is ON, check for correct wiring connections.

- Note -

The following paragraph describes the data processing algorithm that must be followed to insure proper operation of the Sentry™ over its operating range!

A simplified data processing algorithm is provided as guidance:

- Read sensor output voltage every few seconds
- Limit the sensor output to the full-scale range using an "IF, THEN" type logic statement. "IF" the sensor output voltage is "<" the value shown, "THEN" set the sensor voltage to the value shown in Table 3.2-2 above. Else, set the voltage reading to actual reading.
- Convert to visibility in correct units of measure using formulas provided
- Compute running average of 3-5 minutes
- Archive averaged data once per minute

Table 3.2-3 below shows the relationship between sensor output current, extinction coefficient (EXCO), and equivalent MOR (visibility) in kilometers, meters, and statute miles, and feet for both the standard 30m - 16 km visibility range and 0-10 VDC and 0-5 VDC voltage outputs. Table 3.2-4 repeats this information for the optional 10m - 10 km visibility range.

Table 3.2-3

SENTRY™ VISIBILITY SENSOR OUTPUT
Standard 30 - 16 Km Visibility Range

Sentry™ Voltage	Output Current (ma)	EXCO (km-1)	MOR (km)	MOR (m)	MOR (mi)	MOR (ft)
10.0000	20.000	100.000	0.0300	30	0.019	98
9.0000	18.400	90.000	0.0333	33	0.021	109
8.0000	16.800	80.000	0.0375	38	0.023	123
7.0000	15.200	70.000	0.0429	43	0.027	141
6.0000	13.600	60.000	0.0500	50	0.031	164
5.0000	12.000	50.000	0.0600	60	0.037	197
4.0000	10.400	40.000	0.0750	75	0.047	246
3.0000	8.800	30.000	0.1000	100	0.062	328
2.0000	7.200	20.000	0.1500	150	0.093	492
1.0000	5.600	10.000	0.3000	300	0.186	984
0.7500	5.200	7.500	0.4000	400	0.249	1312
0.5000	4.800	5.000	0.6000	600	0.373	1969
0.2500	4.400	2.500	1.2000	1200	0.746	3937
0.1000	4.160	1.000	3.0000	3000	1.864	9843
0.0500	4.080	0.500	6.0000	6000	3.728	19686
0.0400	4.064	0.400	7.5000	7500	4.661	24607
0.0300	4.048	0.300	10.0000	10000	6.214	32810
0.0250	4.040	0.250	12.0000	12000	7.457	39372
0.0200	4.032	0.200	15.0000	15000	9.321	49215
0.0187	4.030	0.187	16.0858	16086	9.996	52777

Table 3.2-4

SENTRY™ VISIBILITY SENSOR OUTPUT
Optional 10m..10 Km Visibility Range

Sentry™ Voltage	Sentry™ Current (ma)	EXCO (km-1)	MOR (km)	MOR (m)	MOR (mi)	MOR (ft)
10.0000	20.000	300.000	0.010	10	0.006	33
9.0000	18.400	270.000	0.011	11	0.007	36
8.0000	16.800	240.000	0.013	13	0.008	41
7.0000	15.200	210.000	0.014	14	0.009	47
6.0000	13.600	180.000	0.017	17	0.010	55
5.0000	12.000	150.000	0.020	20	0.012	66
4.0000	10.400	120.000	0.025	25	0.016	82
3.0000	8.800	90.000	0.033	33	0.021	109
2.0000	7.200	60.000	0.050	50	0.031	164
1.2500	6.000	37.500	0.080	80	0.050	262
0.7500	5.200	22.500	0.133	133	0.083	437
0.5000	4.800	15.000	0.200	200	0.124	656
0.2500	4.400	7.500	0.400	400	0.249	1312
0.1000	4.160	3.000	1.000	1000	0.621	3281
0.0500	4.080	1.500	2.000	2000	1.243	6562
0.0450	4.072	1.350	2.222	2222	1.381	7291
0.0400	4.064	1.200	2.500	2500	1.554	8202
0.0350	4.056	1.050	2.857	2857	1.775	9374
0.0300	4.048	0.900	3.333	3333	2.071	10937
0.0250	4.040	0.750	4.000	4000	2.486	13124
0.0200	4.032	0.600	5.000	5000	3.107	16405
0.0150	4.024	0.450	6.667	6667	4.143	21873
0.0125	4.020	0.375	8.000	8000	4.971	26248
0.0100	4.016	0.300	10.000	10000	6.214	32810

3.3 74024X 3-Relay Output (Optional)

When installed, various relay options are available. These are indicated by a suffix as follows.

Table 3.3-1

The suffix is	Then your output is
C	1 Control Relay
D	Diagnostic Relay
E	2 Control Relays
F	1 Control, 1 Diagnostic Relay
G	2 Control, 1 Diagnostic Relay

Control Relay #1 Suffix C, F

The customer must set the threshold of the control relay #1. If both control relays were ordered, set Control Relay #1 to the higher of the 2 control relay thresholds, i.e. 3000 m). Figure 3.3-1 and the procedure steps below provide the details of setting up the control relay threshold.

1. Select the visibility at which the control relay should activate. Use the formulas in Section 3.1 and Table 3.1-1 for a 0-10 VDC output sensor to determine an equivalent sensor output voltage. For example, the equivalent sensor voltage for a threshold of 3 kilometers is calculated as follows:

Sensor VDC = $0.300 / 3 \text{ km} = 0.100 \text{ VDC}$	30m – 16 km standard visibility range
Sensor VDC = $0.100 / 3 \text{ km} = 0.033 \text{ VDC}$	10m – 10 km optional visibility range

2. Connect a digital voltmeter (DVM) to TP2 (-) and TP8 (+).
3. Adjust R13 to set the threshold voltage to the voltage obtained above.
4. To test the relay, connect an ohmmeter to across the CCOM1 and CNO1 terminals of TB1.
5. Wave your hand in the Sentry™ sample volume to increase the sensor output and observe that the ohmmeter switches from “open” to “short”.

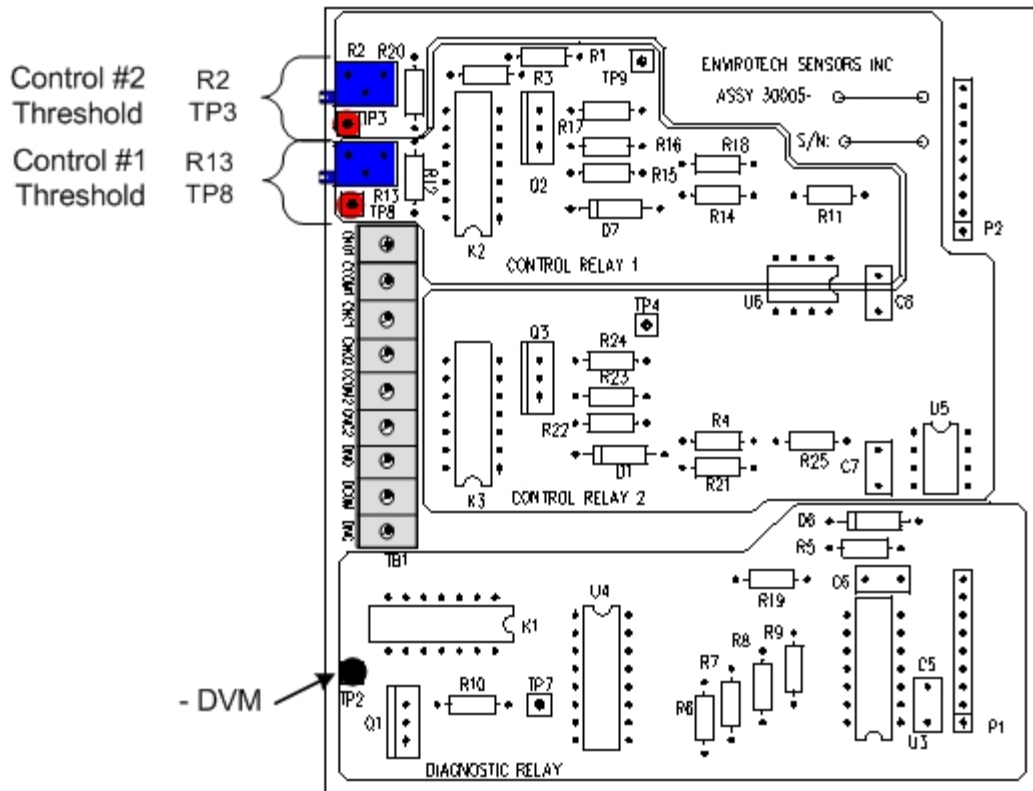

Figure 3.3-1 3-Relay Control Relay Adjustment Points

Control Relay #2 Suffix E, G

The customer must set the threshold of the control relay #2. Set this relay to the lower of the 2 control relay thresholds, i.e. 1 km). Figure 3.3-1 and the procedure steps below provide the details of setting up the control relay threshold.

1. Select the visibility at which the control relay should activate. Use the formulas in Section 3.1 and Table 3.1-1 for a 0-10 VDC output sensor to determine an equivalent sensor output voltage. For example, the equivalent sensor voltage for a threshold of 1 kilometers is calculated as follows:

Sensor VDC = 0.300 / 1 km = 0.300 VDC	30m – 16 km standard visibility range
Sensor VDC = 0.100 / 1 km = 0.100 VDC	10m – 10 km optional visibility range

2. Connect a digital voltmeter (DVM) to TP2 (-) and TP3 (+).
3. Adjust R2 to set the threshold voltage to the voltage obtained above.
4. To test the relay, connect an ohmmeter to across the CCOM2 and CNO2 terminals of TB1.
5. Wave your hand in the Sentry™ sample volume to increase the sensor output and observe that the ohmmeter switches from “open” to “short”.

Diagnostic Relay Suffix D, F, G

Once the diagnostic relay is connected to the user system, no further operation is required. The diagnostic relay provides a basic indication of Sentry™ status. If the relay activates, the sensor has detected a problem with DC input power, sensor derived voltages, or transmitter function. See Section 5.4 for assistance on corrective maintenance.

- Note -

For applications used to control foghorn or warning lights, it is recommended that the user supplied control system activate only after sensing several continuous minutes of activated relay closure from the Sentry™ sensor. This will prevent momentary inadvertent activations of the warning system.

4.0 Calibration

The Sentry™ is initially calibrated at the factory using a standard Calibraton Fixture. It is recommended that the calibration be checked during the field installation and every 6 months afterward. The calibration procedure should be performed when the visibility is $>1/2$ mile, with no precipitation.

The 73062 Calibration Fixture, shown in Figure 4.0-1, is used to check the sensor calibration. The Calibration Fixture consists of portable Attaché Case with 1) Foam Light Block for checking the sensor zero, 2) Neutral Density (ND4) Filter for checking the sensor span, 3) Scatter Plate used in conjunction with the ND Filter for checking the sensor span, and 4) thumb nuts for attaching the Scatter Plate to the mounting studs on the back of the Main Electronics Enclosure. Three (3) thumbnuts are provided, 2 for use to hold the Scatter Plate and 1 as a spare. Any $1/4$ -20 hex nut can also be used but the thumbnuts are easier to use and require no tools. The Calibration Fixture is assigned a factory traceable extinction coefficient (EXCO) that is recorded on the ND4 Filter and the Scatter Plate.

Equipment Needed:

- *73062 Calibration Fixture*
- *Clean cloth*
- *Window cleaning solution*
- *Common hand tools*

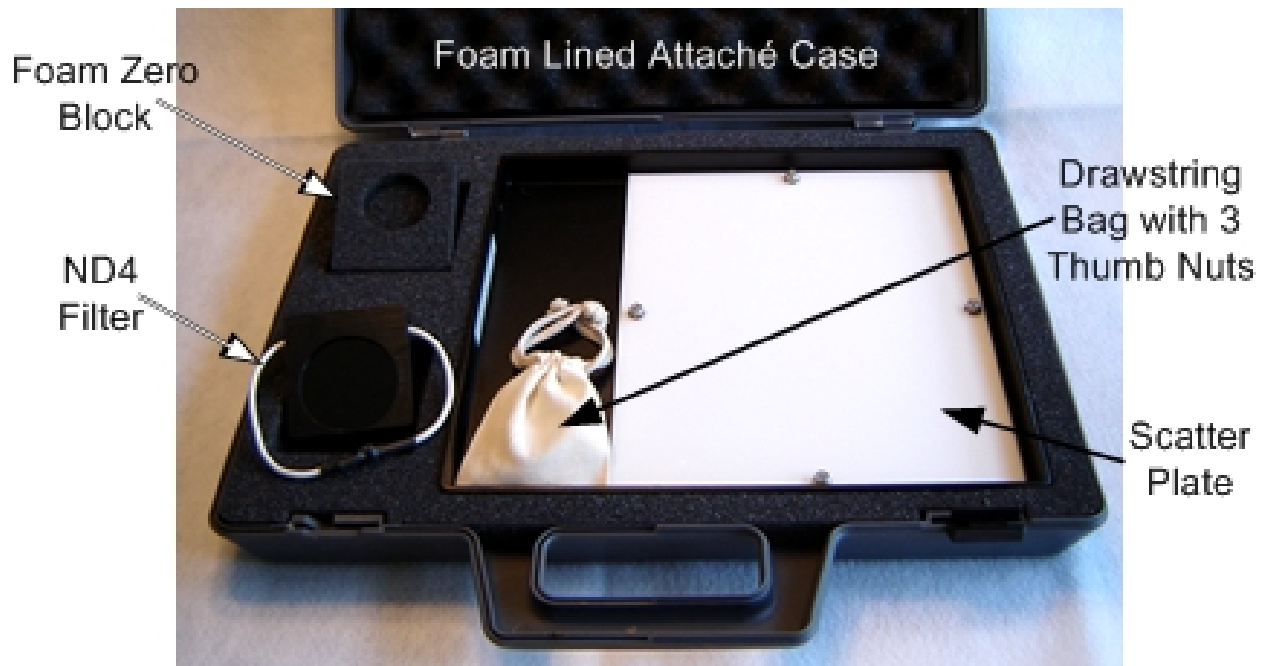

Figure 4.0-1 73062 Calibration Fixture

For analog output voltage sensors, go to Section 4.1.

For 4-20 ma current output sensors, go to Section 4.2

4.1 Procedure for Calibrating the Analog Voltage Output Sentry™ Sensor

Note - This procedure may be used for the 0-5 VDC and 0-10 VDC analog outputs.

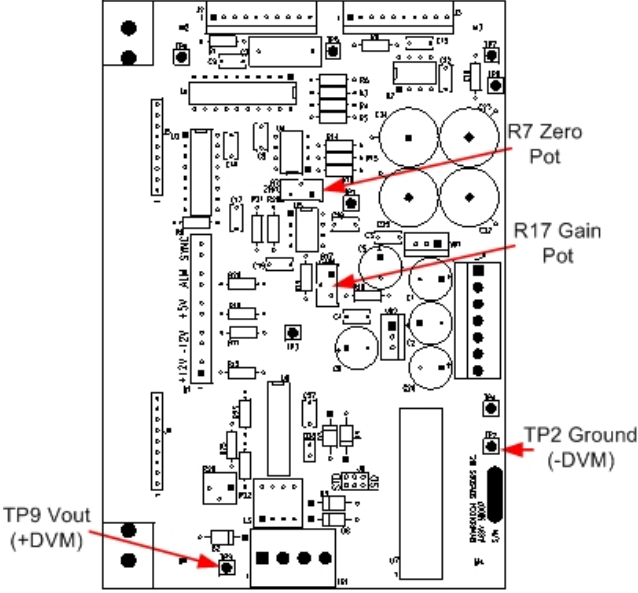
Step	Procedure
1	Inspect the Scatter Plate and ND4 Filter to insure they are clean, free of scratches, mechanically sound, and have matching serial numbers. If you are uncertain about the integrity of the Calibration Fixture, contact R.M. Young Company for information about returning it for service.
2	<i>Clean the sensor windows with common window cleaner and remove any insect nests, spider webs or other debris under the hoods to ensure that the optical path is clear. If 73038 Hood Extensions are installed, loosen the retaining screw and remove them before cleaning the lenses. Leave then off until the calibration is complete.</i>
3	If the sensor was off, turn the sensor power ON and wait at least 30 minutes.
4	<p>Connect a digital voltmeter (DVM) with 4-½ digit resolution to the inputs of the customer data acquisition (DA) system. <i>Connecting at the DA system will more accurately reflect what the DA system is measuring. A 1 mV offset can cause a large difference at the 10-mile full-scale output of the Sentry™.</i> If unable to connect to the data acquisition system inputs, connect to TP9 (+) and TP2 (-) of the Signal Processing PCB as shown in Figure 4.1-1.</p>  <p style="text-align: center;">Figure 4.1-1 Calibration Test Points and Adjustment Points</p>
5	<p><u>Install the Foam Light Block</u> securely over the receiver optics by pushing it up under the hood and against the optics to completely block any incoming light. The Light Block is concave so that it completely covers the protruding glass lens. It is very important that the plug completely block out all incoming light. Even very small amounts of stray light may cause the offset to be affected.</p> <p style="text-align: center;">--- NOTE ---</p> <p><i>Never install the Scatter Plate during the zero check because the scattered signal is so intense that some of the light may reach the receiver. If in doubt about the zero, cover the transmitter and receiver heads with a cloth to verify that the zero stabilizes near 0 mV before proceeding.</i></p>

6	Wait 5 minutes for the signal to stabilize.
7	Read the DVM and adjust R7 (Zero Pot) of the Signal Processing PCB to 0.0 +/- 0.5 mV.
8	Remove the Foam Light Block and store it in the Attaché Case.
9	<p>Install the ND4 Filter securely over the receiver optics by pushing it up under the hood and against the optics to completely block any incoming light. Stretch the elastic cord around the back of the RX Head to hold the filter in place as shown in Figure 4.1-2.</p> <div data-bbox="532 466 1198 737" data-label="Image"> </div> <p style="text-align: center;">Figure 4.1-2 Installation of ND4 Filter</p>
10	<p>Install the Scatter Plate on the threaded studs on the back of the Main Electronics Enclosure using the thumbnuts supplied in the 73062 Calibration Fixture as shown in Figure 4.1-3. Note the Scatter Plate orientation. The Plate installs with the ¼" circular mounting hole on the top stud and the ¼" slot on the bottom stud. When installed correctly, the top of the plate will be flush with the top of the sensor cross arm.</p> <div data-bbox="300 1010 1382 1724" data-label="Diagram"> </div> <p style="text-align: center;">Figure 4.1-3 Installing the Scatter Plate</p>
11	Wait 5 minutes for the signal to stabilize.
12	Record the EXCO written on the Calibration Fixture: EXCO = _____/km

13	<p>Compute the equivalent sensor calibration voltage from the EXCO above as follows:</p> <p style="text-align: center;"><u>Standard Visibility Range of 30m – 16 km</u></p> <ul style="list-style-type: none"> • For 10 VDC full-scale output sensors with W: Sensor Cal Voltage = EXCO / 10 = _____ VDC • For 5 VDC full-scale output sensors with V: Sensor Cal Voltage = EXCO / 20 = _____ VDC <p style="text-align: center;"><u>Optional Visibility Range of 10m – 10 km</u></p> <ul style="list-style-type: none"> • For 10 VDC full-scale output sensors with W: Sensor Cal Voltage = EXCO / 30 = _____ VDC • For 5 VDC full-scale output sensors with V: Sensor Cal Voltage = EXCO / 60 = _____ VDC <p><i>Remember that the visibility range of the Sentry™ is usually 16 km. If the range is the optional 10 km, it will be marked on the inside of the Main Electronics Enclosure.</i></p>
14	Read the DVM and adjust R17 (Span Pot) of the Signal Processing PCB to the calculated cal voltage recorded in Step 13, +/-1 mV.
15	Remove the Scatter Plate and ND4 Filter return all parts to the Attaché Case.
16	Disconnect the DVM from the DA System or Signal Processing PCB.
17	Close and secure the door of the Main Electronics Enclosure.
18	If used, reinstall the 73038 Hood Extensions.

4.2 Procedure for Calibrating the Sentry™ with 4-20 ma Current Output

Note - This procedure may be used with either the standard single ended or the isolated 4-20 ma current output.

Step	Procedure
1	Inspect the Scatter Plate and ND4 Filter to insure they are clean, free of scratches, mechanically sound, and have matching serial numbers. If you are uncertain about the integrity of the Calibration Fixture, contact R.M. Young Company for information about returning it for service.
2	<i>Clean the sensor windows with common window cleaner and remove any insect nests, spider webs or other debris under the hoods to ensure that the optical path is clear. If 73038 Hood Extensions are installed, loosen the retaining screw and remove them before cleaning the lenses. Leave them off until the calibration is complete.</i>
3	If the sensor was off, turn the sensor power ON and wait 30 minutes.
4	Connect a digital current meter with 4-½ digit resolution to the 4-20 ma output of TB1 of the Signal Processor PCB as shown in Figure 2.3.2-1.
5	Install the Foam Light Block securely over the receiver optics by pushing it up under the hood and against the optics to completely block any incoming light. The Light Block is concave so that it completely covers the protruding glass lens. It is very important that the plug completely block out all incoming light. Even very small amounts of stray light may cause the offset to be affected. --- NOTE --- <i>Never install the Scatter Plate during the zero check because the scattered signal is so intense that some of the light may reach the receiver. If in doubt about the zero, cover the transmitter and receiver heads with a cloth to verify that the zero stabilizes near 0 mV before proceeding.</i>
6	Wait 5 minutes for the signal to stabilize.
7	Read the DVM and adjust R7 (Zero Pot) of the Signal Processing PCB to 4.000 ma.
8	Remove the Light Block and store it in the Attaché Case.
9	Install the ND4 Filter securely over the receiver optics by pushing it up under the hood and against the optics to completely block any incoming light. Stretch the elastic cord around the back of the RX Head to hold the filter in place as shown in Figure 4.1-2.
10	Install the Scatter Plate on the threaded studs on the back of the Main Electronics Enclosure using the thumbnuts supplied in the 73062 Calibration Fixture as shown in Figure 4.1-3. Note the Scatter Plate orientation. The Plate installs with the ¼" circular mounting hole on the top stud and the ¼" slot on the bottom stud. When installed correctly, the top of the plate will be flush with the top of the sensor cross arm.
11	Wait 5 minutes for the signal to stabilize.

5.0 Maintenance

5.1 R.M. Young Company Product Warranty:

Warranty

R.M. Young Company (Seller) warrants this Sentry Visibility Sensor to be free of defects in material and workmanship under normal conditions for a period of twenty-four (24) months from date of shipment subject to the following:

- *Warranty does not apply to products that have been subject to mishandling, misapplication, modification, abuse, neglect, accident of nature, or shipping damage.*
- *The Seller is not liable for incidental or consequential damage caused by its products including but not limited to: damages for loss of use, income, profit, or good will; losses sustained as a result of death or injury to any persons; and/or damages to property other than the product. In no case shall the Seller's liability exceed the price paid for the product.*
- *This warranty is expressly in lieu of any other expressed or implied warranty of merchantability or fitness for a particular purpose, and of any obligations or liabilities on the part of the Seller or its employees or agents.*

5.2 Correcting Defects Under the Warranty

Contact R.M. Young Company to discuss the reason for returning a product and to obtain the return material authorization (RMA) number. Items to be returned to R.M. Young Company for any reason must be accompanied by a return material authorization number. Mark the outside of all shipping cartons and correspondence with the RMA number.

Buyer shall return the product to R.M. Young Company, prepaid transportation. Upon receipt, R.M. Young Company will evaluate the product to determine the cause of the reported problem and the applicability of the warranty. Products deemed to be covered by the warranty will be repaired by R.M. Young Company at no charge to the Buyer and returned to the Buyer, prepaid surface transportation. R.M. Young Company will prepare an estimate for products not under warranty and submit the quotation to the Buyer for approval.

Contact R.M. Young Company or visit <http://www.youngusa.com> for information on the return of waste electrical parts per WEEE (The Waste Electrical and Electrical Equipment Directive) directive 2002/96/EC.



5.3 Preventative Maintenance

Regular field maintenance is recommended to keep the Sentry™ in good working order. In most operating environments, quarterly (120 day) maintenance is recommended. Calibration, as described in Section 4 is performed every six (6) months. Each user should select the maintenance frequency that meets their needs. In some road weather applications where the sensor is exposed to wet, dirty spray from passing vehicles, it may be necessary to clean the optics more frequently. **If 73038 Hood Extensions are installed, loosen the retaining screw and remove them before cleaning the lenses.**

Typical Preventative Maintenance Schedule

	Installation	3 month	3 month	3 month	3 month
Clean Lenses		YES	YES	YES	YES
Calibrate	YES		YES		YES

Remember that the sensor output data will be incorrect during the maintenance activities. Either turn the sensor power off or note the date and time of the maintenance for later reference.

Equipment Needed:

- *Soft cloth*
- *Window cleaning solution*
- *Common hand tools*

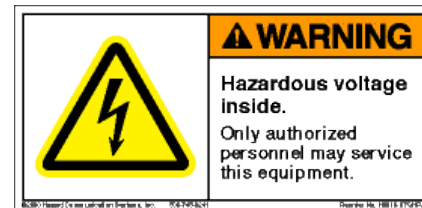

Procedure:

1. Using a straight blade screwdriver, loosen the two (2) screws that secure the door on the Main Electronics Enclosure.
2. On AC powered units, observe that the green LED on the AC Power Supply is lit. On DC powered units, follow step 3.
3. Observe that the first three (3) green LEDs are lit on D1 of the Signal Processor PCB. Observe that the last LED is blinking at approximately 1 Hz (once per second). Refer to Figure 5.4.1-1.
4. Use caution when following the steps below. If it is below ~ 5° C (40° F), the external hood heaters may be **HOT**. Turn sensor power off before proceeding.
5. Using the soft cloth, clean the area under the TX and TX hoods. Look before you reach under the hoods for wasp or beehives!
6. Clean away any old spider webs that are on the sensor cross arm, heads and enclosure.
7. Spray the TX and RX lenses liberally with the window cleaner and wipe thoroughly with a soft, clean cloth.
8. If the power was turned off, turn it back ON and observe the indicator lights per step 3.
9. Close the Main Electronics Enclosure door and tighten the two (2) screws to secure the door.

--- A Note About Spiders ---

Spiders can be a problem at certain times of the year. They may leave webs that cross the sensor's optical path causing inaccurate readings. There appear to be no product available on the market today that will completely eliminate spider infestations.

5.4 Corrective Maintenance

5.4.1 Initial Checks

1. Open the Main Electronics Enclosure by loosening the 2 captive screws on the cover.
2. On AC versions, observe that the green LED on the AC Power Supply is ON.
3. Observe LED array on the Signal Processor PCB. It should be illuminated as shown in Figure 5.4.1-1. The ALM LED is only used with the 4-20 ma option. If correctly wired, the ALM LED should be OFF.
4. If the red LED on the AC Surge Protection Module is ON, go to Section 5.4.4 to replace the module.

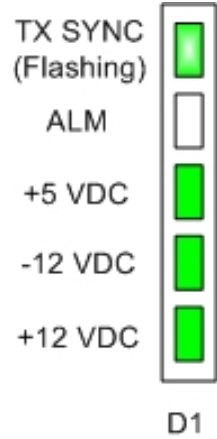

Figure 5.4.1-1 LED Display

5.4.2 Test Points

Equipment required:

- 3-1/2 Digit Digital Volt Meter
 - Oscilloscope
1. Measure the power supply voltages at TP1, TP3, & TP4 of the Signal Processor PCB as indicated in Figure 5.4.2-1 and verify that they are within tolerance as listed in Table 5.4.2-1. Use TP2 as the ground reference.
 2. If LED 5 is not blinking ~30 times per minute (1/2 Hz) measure the SYNC pulse at TP6 using an oscilloscope. If the SYNC is out of tolerance, replace the sensor per the general installation instructions in Section 2.

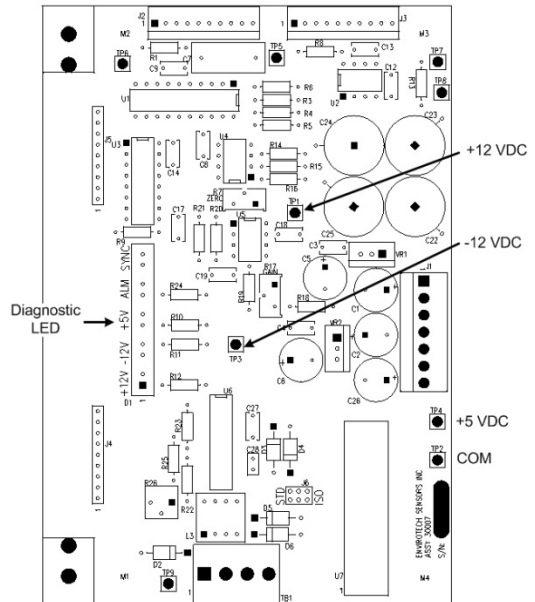

Figure 5.4.2-1 Signal Processor Diagnostic Test Points

Table 5.4.2-1

LED	Status	Indication	Test Point	Tolerance
1	ON	+12 VDC	TP 1	12.0 +/- 0.5 VDC
2	ON	-12 VDC	TP 3	-12.0 +/- 0.5 VDC
3	ON	+5 VDC	TP 4	5.0 +/- 0.25 VDC
4	OFF	4-20 ma	---	OFF = normal, ON = incomplete current loop
5	BLINKING	SYNC	TP 6	5 Vp-p @ 2600 +/- 200 Hz

AC Versions - If TP1, TP3, or TP4 are out of tolerance, measure the voltages from the main AC Power Supply as shown in Figure 5.4.2-2 and the Table 5.4.2-2 below. Use the power supply terminal marked “Com” as the ground reference.

Table 5.4.2-2

Name	Wire Color	Tolerance
+V2	Red	15.0 +/-0.5 VDC
COM	Black	15 VDC Return
V3	White	-15.0 +/-0.5 VDC
+5V	Green	5.0 +/-0.25 VDC

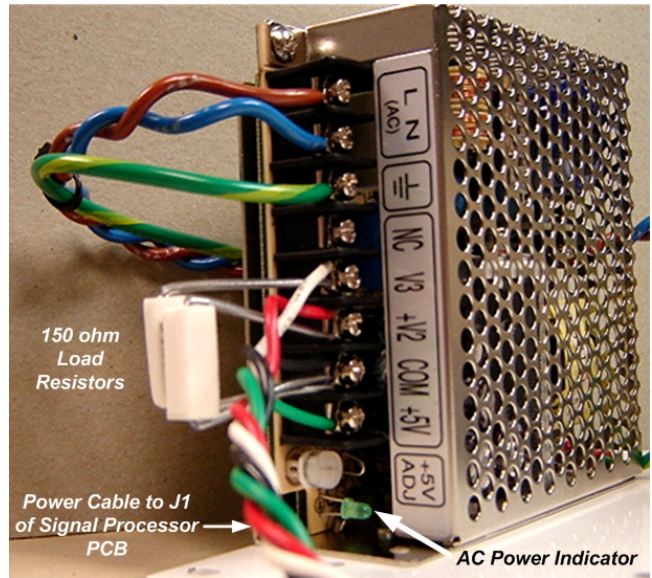

Figure 5.4.2-2 AC Power Supply Test Points

1. If the AC Power Supply voltages are within tolerance but the Signal Processor voltages are out of tolerance, replace the sensor per the general installation instructions in Section 2.
2. If the AC Power Supply voltages are out of tolerance, replace the AC Power Supply per the remove & replace instructions in Section 5.4.4.

DC Versions – Verifying the DC power supply tolerances.

--- Note ---

*When measuring the 10-36VDC input, use the GND terminal of TB1 as the reference.
When measuring TP3, TP4, and TP5 output voltages, use TP2 as the reference.*

Table 5.4.2-3

Test Point	Tolerance
T1 Power Input	10-36 VDC
TP3	+15.0 +/-0.5 VDC
TP4	-15.0 +/-0.5 VDC
TP5	5.0 +/-0.25 VDC

If TP3, TP4, or TP5 are out of tolerance, replace the DC Power Supply board per section 5.4.4.

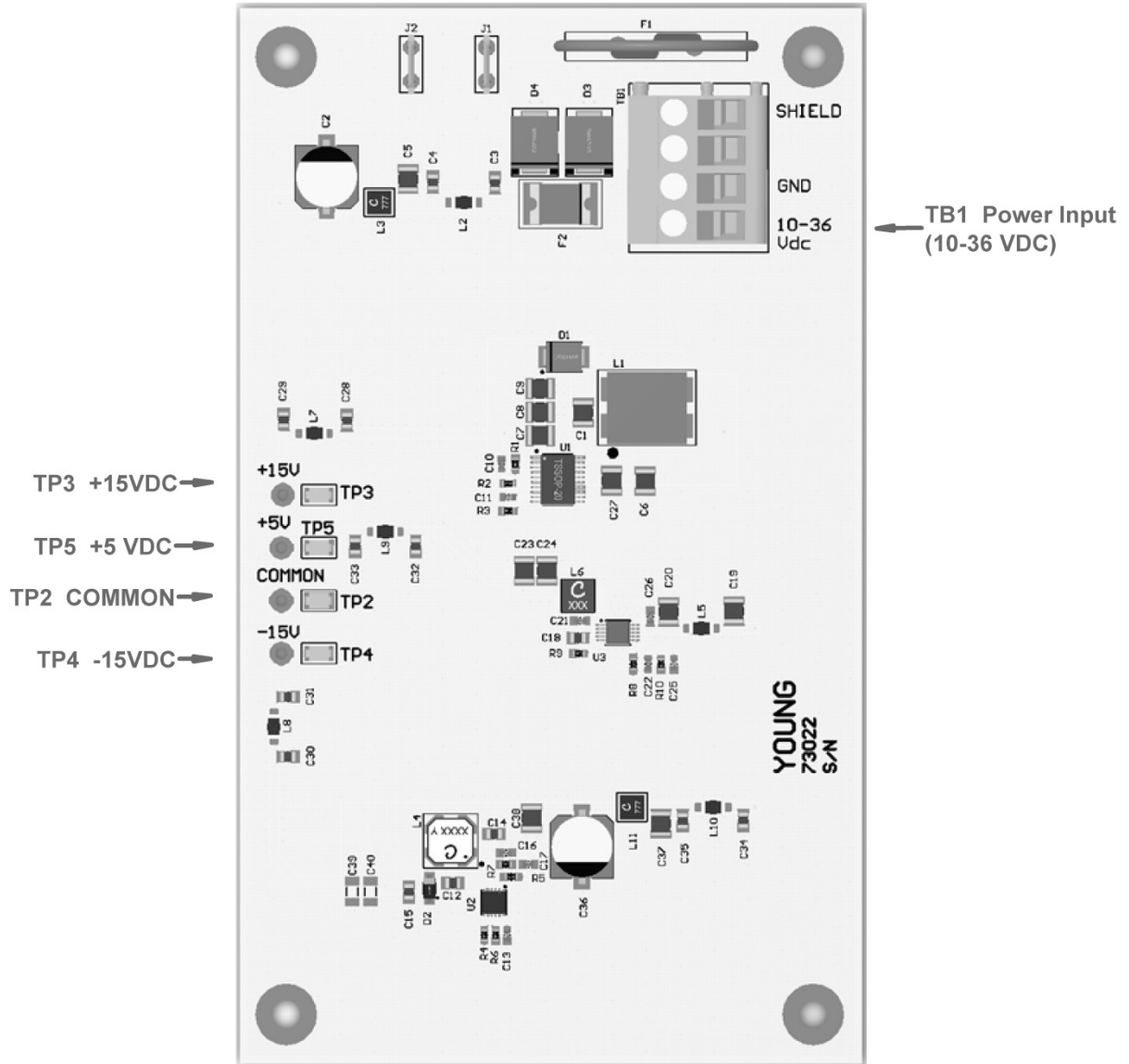

Figure 5.4.2-3 DC Power Supply Test Points

5.4.3 Troubleshooting Scenarios

These scenarios assume that the power supply and test point checks described above have been completed.

Case 1 - Visibility too high (sensor analog output too low) for long periods when it is obvious that the ambient visibility is low (i.e. foggy).

- Clean the lenses – this is the most likely cause of the measured visibility being too high!
- Check for lens blockage due to snow or wet blowing leaves – clear as needed.
- Check for lens heater operation by feeling the lens with your finger. The lens should be warmer than the TX/RX head area around the heated lens – replace sensor if lens heater not operational or condensation continues to be a problem.
- Check for physical damage to the sensor heads or cross arm. Misalignment of these parts will result in TX and RX beams not intersecting correctly – replace sensor.
- Calibration required – see Section 4 for procedure
- Problem could be internal to the sensor – replace sensor per the general installation instructions in Section 2.

Case 2 - Visibility too low (sensor analog output too high) for long periods when it is obvious that ambient visibility is high (i.e. clear).

- Check for spider webs or insect nests under the hoods or anywhere within the sensor sample volume – clean as needed.
- Check for other sources of interference that would cause light scattering such as physical damage to hoods or other parts of the head – remove interference or replace sensor as needed.
- Calibration required – see Section 4 for procedure
- Problem could be internal to the sensor – replace sensor per the general installation instructions in Section 2.

5.4.4 Remove & Replace Instructions

Only certain parts of the Sentry™ may be replaced in the field. The TX and RX Heads are not field repairable and should not be opened. The Signal Processor PCB in the Main Electronics Enclosure is not field replaceable. Contact R.M. Young Company if you have a question about what is repairable or replaceable in the field.

Instructions to remove and replace Sentry's components are listed below. Remember that the Sentry™ contains hazardous mains voltages and should only be serviced by authorized personnel who have fully read and understand this User's Guide.

Equipment required:

- Flat blade screwdrivers
- #2 Phillips screwdriver
- 3/8" nut driver
- Adjustable wrench
- Needle nosed pliers
- Wire cutters

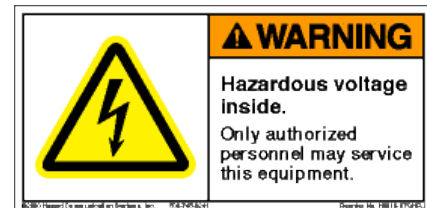

Surge Protection Module - Turn AC or DC power OFF before proceeding with the removal and replacement instructions provided in this Section!

- Removal - Using a small flat blade screwdriver, loosen the 3 AC input wires on the left side of the module. Loosen the 3 AC output wires from the right side of the module. Loosen the hold down screw on the lower DIN rail clamp and lift the clamp off the rail to free the module. Slide the module down and off the rail.
- Replacement – Place the new module over the DIN rail with the “protected side” on the right. Clip the left side over the left side of the DIN rail and lower the right side until it clips on the rail. Slide the lower DIN rail clamp up against the new module and tighten its hold down screw to secure the surge module. Wire the module per Figure 5.4.4-1 and refer to Section 2.3.1 for additional information.
- Calibrate the sensor per Section 4 before returning the Sentry™ to service.

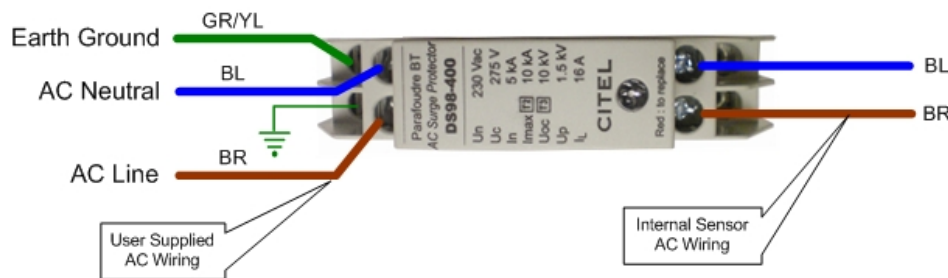

Figure 5.4.4-1 Surge Module Wiring

AC Power Supply - *Turn AC or DC power OFF before proceeding with the removal and replacement instructions provided in this Section!*

- Removal – Disconnect the signal wiring from TB1 terminal board on the Signal Processor PCB or output option board if installed. Using a small flat blade screwdriver, loosen the 3 AC input wires on the left side of the surge module. Using a 3/8" nut driver, loosen the hex nut on the 10-32 ground screw located in the lower right corner of the base plate. Lift off the green/yellow wire that connects to the Main Enclosure ¼-20 ground stud. Using a long flat blade screwdriver, unscrew the 4 white base plate corner screws. Carefully tip the base plate assembly out of the enclosure. Unplug the white 7-pin connector from J1 on the right side of the Signal Processor PCB. Using a small flat blade screwdriver, loosen the blue and brown AC wires on the right side of the power supply. Loosen the 2 screws that secure the AC Power Supply to the base plate.
- Replacement – Install and tighten the 2 screws that secure the new AC Power Supply to the base plate. Plug the white 7-pin connector into J1 of the Signal Processor PCB. Reinstall the base plate assembly into the enclosure and tighten the 4 corner screws securely. Reconnect the green/yellow ground wire from the Main Enclosure ground stud to the base plate ground stud. Rewire the AC power input per Figures 5.4.2-2 and A1 as needed. Rewire the user signal wires per Section 2.4.
- Calibrate the sensor per Section 4 before returning the Sentry™ to service.

DC Power Supply - *Turn AC or DC power OFF before proceeding with the removal and replacement instructions provided in this Section!*

- Removal – Using a small flat blade screwdriver, loosen the 2 DC input power wires from TB1 of the DC Power Supply PCB. Unplug the white 7-pin connector from J1 on the right side of the Signal Processor PCB. Using a small flat blade screwdriver, unscrew the 4 corner screws that hold the DC Power Supply PCB to the base plate. Carefully lift the PCB out of the enclosure.
- Replacement – Place the new DC Power Supply PCB over the base plate standoffs and replace the 4 screws and washers to secure it. Plug the white 7-pin connector into J1 of the Signal Processor PCB. Rewire the DC power input wires to TB1 per Section 2.3.2.
- Calibrate the sensor per Section 4 before returning the Sentry™ to service.

Output Option PCB - Turn AC or DC power OFF before proceeding with the removal and replacement instructions provided in this Section!

- Removal – Using a small flat blade screwdriver, loosen the 2 signal wires from TB1 and/or TB2 of the Output Option PCB. Carefully slide the PCB out of the card guides of the Signal Processor PCB.
- Replacement – Place the new Output Option PCB into the card guides of the Signal Processor PCB and carefully seat the mating connectors. Rewire the user signal wires to TB1 and/or TB2 per Section 2.4.2.
- Calibrate the sensor per Section 4 before returning the Sentry™ to service.

5.5 Field Replaceable Units (FRU's)

Only certain parts of the Sentry™ may be replaced in the field. The TX and RX Heads are not field repairable and should not be opened. The Signal Processor PCB in the Main Electronics Enclosure is not field replaceable without factory training. Table 5.5-1 provides a list of the field replaceable units. Contact R.M. Young Company for information about what FRUs are applicable to your Sentry™.

Table 5.5-1

FRU Description	FRU P/N
AC Surge Protection Module	74031-02
Switching AC Power Supply Assy	73031-02
DC Power Supply Assy	73022
Signal Processor PCB ^{Note1}	73020X
3-Relay Output Option PCB ^{Note1}	74024X
AC External Hood Heater Transformer	73031-05

Note1 – You must order the exact replacement – see your PCB for complete part number.

5.6 Training

Additional training is available from R.M. Young Company. Custom courses are offered in such areas as visibility theory and practice, siting guidelines, and installation & maintenance. These training courses are available at the R.M. Young Company factory, at the user's facility, or in the field. Contact R.M. Young Company, for more information. Training is recommended for the user to become an authorized and knowledgeable service person.

Appendix

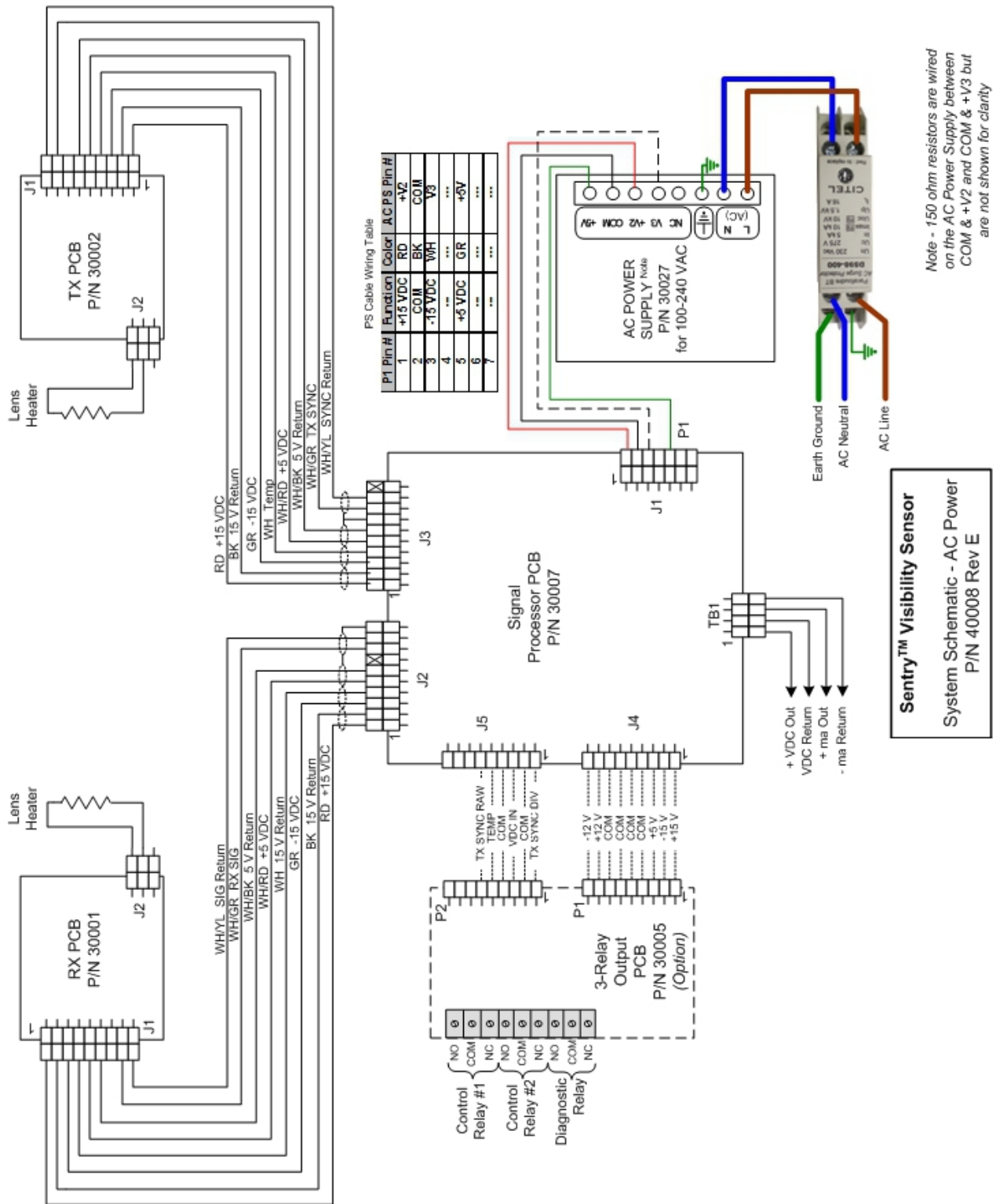

Figure A-1 Sentry™ Schematic – AC Version

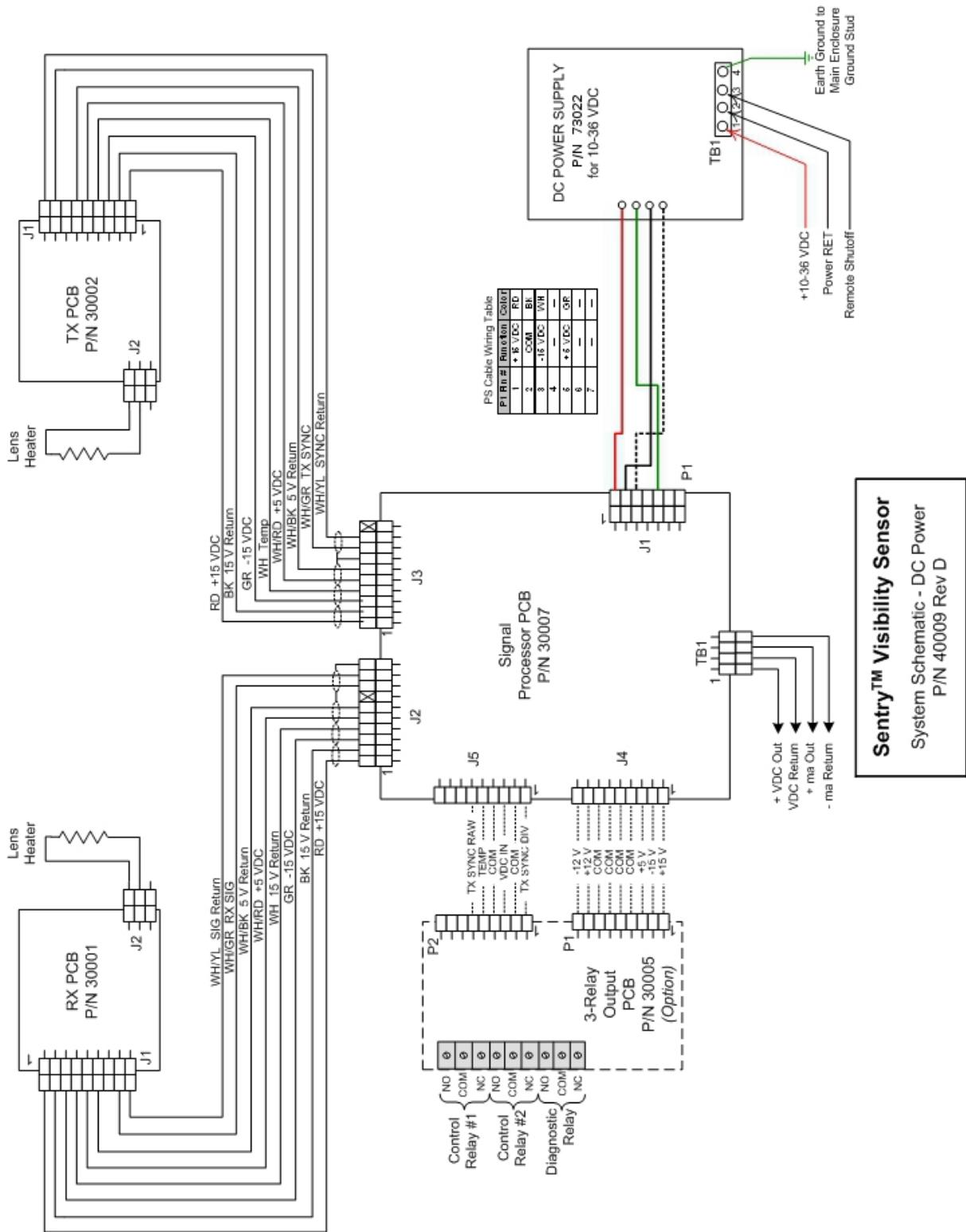

Figure A-2 Sentry™ Schematic – DC Version

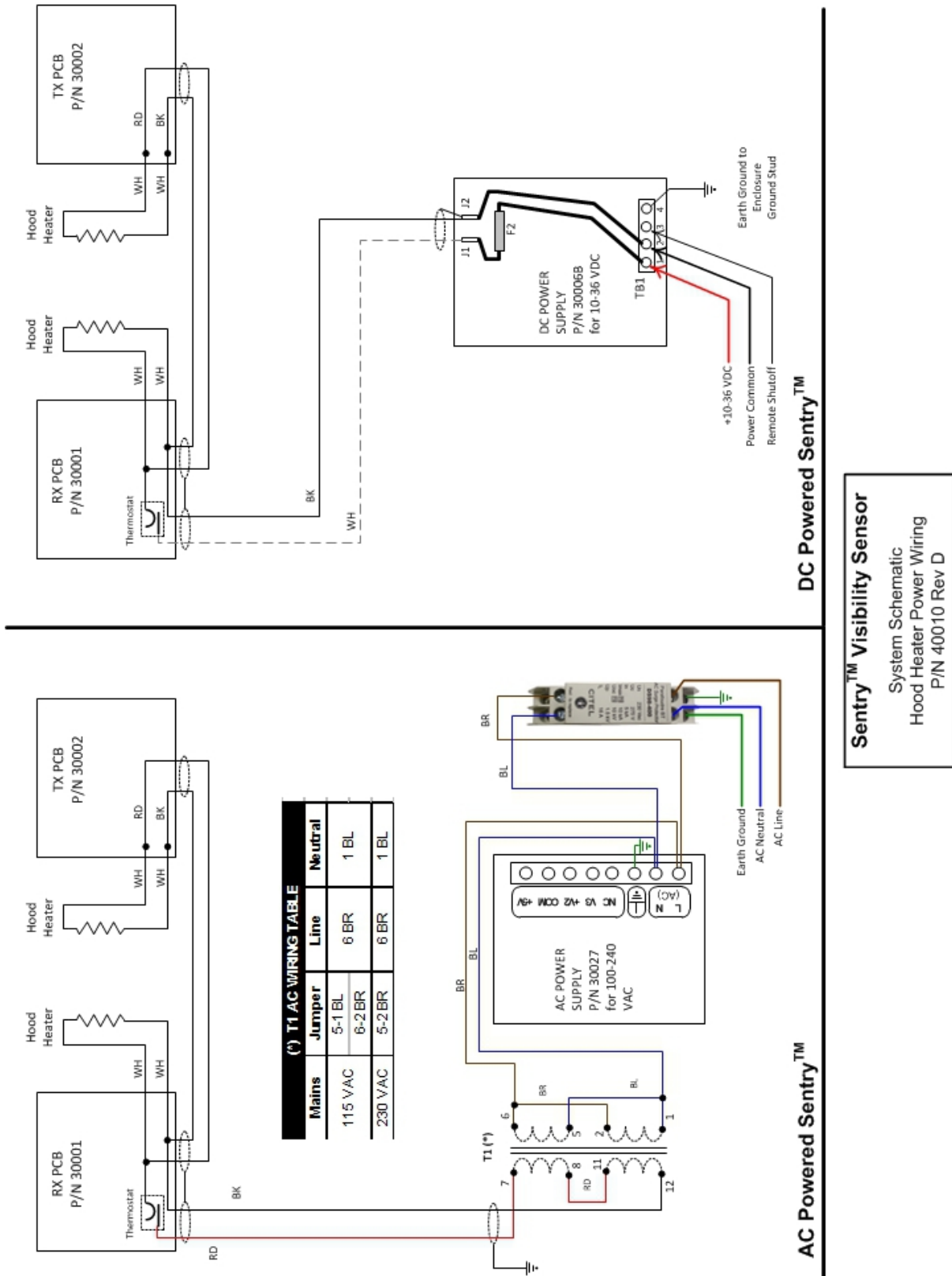

Figure A-3 Sentry™ Schematic – Optional Hood Heaters

Sentry™ Visibility Sensor
System Schematic
Hood Heater Power Wiring
P/N 40010 Rev D